

JHCPB Joint Venture

Soil and Surface Water Management Plan

RIC-JHC-MPL-00-PL-270-001

Project	Design and Construction of Rozelle Interchange Project
Design Lot No.	00-PL-270
Document No.	RIC-JHC-MPL-00-PL-270-001
Revision Date	16 December 2020

Document Approval

Developed By:				
Name: [REDACTED]		[REDACTED]		
Reviewed By:				
Name		Position		Date Reviewed
[REDACTED]		[REDACTED]		[REDACTED]
Revision Record				
Rev	Rev Date	Reason for issue	Developed by	Approved by
A	26/03/2019	[REDACTED]	[REDACTED]	[REDACTED]
B	05/04/2019	[REDACTED]	[REDACTED]	[REDACTED]
C	02/05/2019	[REDACTED]	[REDACTED]	[REDACTED]
00	14/05/2019	[REDACTED]	[REDACTED]	[REDACTED]
01	27/06/2019	[REDACTED]	[REDACTED]	[REDACTED]
02	11/07/2019	[REDACTED]	[REDACTED]	[REDACTED]
03	27/08/2020	[REDACTED]	[REDACTED]	[REDACTED]
04	16/12/2020	Monitoring program updated	[REDACTED]	[REDACTED]

Contents

1. Introduction.....	7
1.1. Context.....	7
1.2. Background and project description.....	7
1.3. Environmental management system overview.....	7
2. Purpose and objectives.....	8
2.1. Purpose.....	8
2.2. Objectives	8
2.3. Environmental performance outcomes and targets.....	8
3. Environmental requirements	10
3.1. Relevant legislation and guidelines	10
3.1.1. Legislation	10
3.1.2. Guidelines and standards	10
3.2. Minister’s Conditions of Approval	11
3.3. Revised Environmental Management Measures.....	15
3.4. Consultation	15
4. Existing Environment	20
4.1. Topography and soil characteristics	20
4.1.1. Topography	20
4.1.2. Soil landscapes.....	20
4.1.3. Soil Salinity	21
4.1.4. Acid sulfate soils	21
4.2. Surface water	25
4.2.1. Catchments	25
4.2.2. Water quality.....	26
4.2.3. Sensitive receiving environments.....	27
4.3. Rainfall	30
4.4. Rainfall erosivity factor	30
4.5. Flooding	30
5. Environmental aspects and impacts.....	33
5.1. Construction activities	33
5.2. Impacts	33
5.2.1. Overview.....	33
5.2.2. Soils.....	33
5.2.3. Surface Water Quality.....	36
6. Environmental control measures.....	39

7. Compliance management	51
7.1. Roles and responsibilities	51
7.2. Training	51
7.2.1. Inductions	51
7.2.2. Toolbox training	51
7.3. Monitoring and inspection.....	51
7.3.1. Monitoring.....	51
7.3.2. Inspections	51
7.3.3. Role of Soil Conservationist	52
7.4. Licences and permits	52
7.5. Weather monitoring	53
7.6. Auditing	53
7.7. Reporting.....	53
8. Review and improvement.....	54
8.1. Continuous improvement.....	54
8.2. SSWMP update and amendment	54
9. References	55

Table of Tables

Table 1 Performance outcomes	8
Table 2 Conditions of Approval relevant to this Plan	11
Table 3 Summary of consultation for development of the SSWMP and the Soil and Surface Water Quality Monitoring Program	16
Table 4 Soil landscape descriptions within Project area	20
Table 5 Locations of ASS or PASS within Project corridor	22
Table 6 Sub-catchments relevant to the Project.....	25
Table 7 Water quality summary.....	27
Table 8 Climate statistics for Observatory Hill (station 66062) from the Bureau of Meteorology	30
Table 9 Monthly % and annual rainfall erosivity (R-factor) values for Rozelle.....	30
Table 10 Summary of potential construction surface water quality impacts (from the M4-M5 Link EIS).....	37
Table 11 Soil and Water management and mitigation measures.....	39
Table 12 Details the proposed reporting schedule	53

Table of Figures

Figure 1 Locations of PASS within the Project corridor	23
Figure 2 Acid sulfate soil map	24
Figure 3 Sub catchments within Project alignment.....	26
Figure 4 Waterfront land near Victoria Road	28

Annexures

Annexure A Other Conditions of Approval and Revised Environmental Mitigation Measures relevant to this Plan	56
Annexure B Surface Water Quality Monitoring Program.....	60
Annexure C Contaminated Land Management Plan.....	61
Annexure D Baseline ESCPs	62

Glossary/ Abbreviations

Abbreviations	Expanded text
AHD	Australian Height Datum
ASS	Acid Sulfate Soil
BOM	Bureau of Meteorology
BTEXN	Benzene, toluene, ethylbenzene, xylene, and naphthalene
CEMP	Construction Environmental Management Plan
CLMP	Contaminated Land Management Plan
CoA	Conditions of Approval
CSSI	Critical State Significant Infrastructure
DPIE	NSW Department of Planning, Industry and Environment
DPI	NSW Department of Primary Industries
DoI Water	Department of Industry – Water (formerly DPI Water)
EC	Electrical Conductivity
EEC	Endangered Ecological Community
EIS	WestConnex M4-M5 Link Environmental Impact Statement
EMM	Environmental Management Measure
EPA	NSW Environment Protection Authority
EPL	Environment Protection Licence
ESCP	Erosion and Sediment Control Plan
EWMS	Environmental Work Method Statement
GMP	Groundwater Management Sub-plan
GWMP	Groundwater Monitoring Program
JHCPB	John Holland CPB Contractors Joint Venture
OEH	Office of Environment and Heritage
PESCP	Progressive Erosion and Sediment Control Plan
PIRMP	Pollution Incident Response Management Plan
POEO Act	<i>Protection of the Environment Operations Act 1997</i>
REMM	Revised Environmental Management Measure
Roads and Maritime	Roads and Maritime Services
RUSLE	Revised Universal Soil Loss Equation
SMCMA	Sydney Metropolitan Catchment Management Authority
SPIR	WestConnex M4-M5 Link Submissions and Preferred Infrastructure Report
SSSWMP	Soil and Surface Water Management Sub-Plan (this document)
SWQMP	Surface Water Quality Monitoring Program
TDS	Total Dissolved Solids
TPH	Total petroleum hydrocarbons
TRH	Total recoverable hydrocarbons
WTP	Water Treatment Plant

1. Introduction

1.1. Context

This Soil and Surface Water Management Sub Plan (this Plan) forms part of the Construction Environmental Management Plan (CEMP) for the Design and Construction of Rozelle Interchange Project (the Project).

This Plan has been prepared to address the requirements of the Ministers Conditions of Approval (CoA), Project Approvals and all applicable guidance and legislation. Background and project description

The Rozelle Interchange project is part of the M4-M5 Link and will provide a new underground motorway interchange with access via City West Link and provide a tunnel connection between Anzac Bridge and Victoria Road, east of Iron Cove Bridge, with links to the future Western Harbour Tunnel. The WestConnex M4-M5 Link EIS (AECOM 2017), specifically Chapter 15, assessed the impacts of construction and operation of the M4-M5 Link Project on soils and water.

As part of the EIS, a detailed flooding and water quality assessment was prepared to address the Environmental Assessment Requirements issued by the Department of Planning and Environment (DPE). The flooding and water quality assessment was included in the EIS as Working Paper 5 – Flooding and Water Quality.

The EIS identified the potential for minor impacts on surface water during construction typically associated with contamination. However, it concluded any potential impacts could be managed by the standard mitigation and management measures that are described in this Plan. The potential minor impacts on surface water during construction are discussed in Section 5.

The Project description is outlined in section 1.3 of the CEMP.

1.2. Environmental management system overview

The environmental management system overview is described in Section 1.5 of the CEMP.

2. Purpose and objectives

2.1. Purpose

The purpose of this Plan is to describe how JHCPB will manage and protect soils and surface water during construction of the Project. This Plan must be read in conjunction with the CEMP and all relevant sub-Plans.

2.2. Objectives

The key objective of this Plan is to ensure all CoAs, REMMs and licence/permit requirements relevant to soil and surface water are described, scheduled and assigned responsibility as outlined in:

- The EIS prepared for WestConnex M4-M5 Link,
- The SPIR prepared for WestConnex M4-M5 Link,
- The Modification Report and Response to Submissions Report prepared for the Mainline Tunnel Modification,
- The Conditions of Approval granted to the Project on the 17th April 2018 and as subsequently modified Roads and Maritime specifications G36, G38 and G40,
- The Project's Environment Protection Licence (EPL# 21278) issued on 18 June 2019 with a Section 58 Licence Variation issued on 18 August 2020, and
- All relevant legislation and other requirements described in Section 3.1 of this Plan.

2.3. Environmental performance outcomes and targets

The desired environmental performance outcome for soil and surface water management, as outlined and addressed in the EIS, is that:

- Long term impacts on surface water are minimised,
- The environmental values of nearby, connected and affected water sources, groundwater and dependent ecological systems including estuarine and marine water (if applicable) are maintained (where values are achieved) or improved and maintained (where values are not achieved),
- The Project is designed, constructed and operated to protect the NSW Water Quality Objectives where they are currently being achieved, and contribute towards achievement of the Water Quality Objectives over time where they are currently not being achieved, including downstream of the Project to the extent of the Project impact including estuarine and marine waters (if applicable),
- The environmental values of land, including soils, subsoils and landforms, are protected, and
- Risks arising from the disturbance and excavation of land and disposal of soil are minimised, including disturbance to acid sulfate soils and site contamination.

To achieve this outcome, JHCPB will undertake the following presented in Table 1.

Table 1 Performance outcomes

No.	Project Outcome	Source	Document Reference
1	Establish water quality discharge criteria with consideration of NSW Water Quality Objectives	EIS, Appendix A	Annexure B
2	Effectively treat water to meet water quality discharge criteria	EIS, Appendix A	Table 11 SSWM3, SSWM5 and SSWM8
3	Erosion and sediment controls will be implemented in accordance with Managing Urban Stormwater – Soils and Construction, Volume 1 (Landcom 2004) and Volume 2D (DECCW 2008), commonly referred to as the 'Blue Book'.	EIS, Appendix A	Table 11 SSWM5

No.	Project Outcome	Source	Document Reference
4	Manage acid sulfate soils in accordance with good practice measures.	EIS, Appendix A	Table 11 SSWM21
5	Manage contamination to protect environmental values and human health.	EIS, Appendix A	Table 11 SSWM22 and SSWM25

3. Environmental requirements

3.1. Relevant legislation and guidelines

3.1.1. Legislation

Legislation relevant to soil and water management for this Project includes:

- *Protection of the Environment Operations Act 1997.*

Relevant provisions of the above legislation are explained in the legal and compliance tracking register included in Annexure A1 of the CEMP.

3.1.2. Guidelines and standards

The main guidelines, specifications and policy documents relevant to this Plan include:

- Acid Sulfate Soil Manual (ASSMAC 1998),
- Acid Sulfate Soil and Rock – Victorian EPA Publication 655.1 – July 2009,
- Australian and New Zealand Guidelines for Fresh and Marine Water Quality (ANZECC and ARMCANZ 2000),
- Australian and New Zealand Environment and Conservation Council and Volume 2A Installation of Services (DECCW 2008a) Volume 2C Unsealed Roads (DECCW 2008b) Agriculture and Resource Management Council of Australia and New Zealand (ANZECC): National Water Quality Management Strategy, Paper No. 4, Australian and New Zealand Guidelines for Fresh and Marine Water Quality, Volume 1, The Guidelines (ANZECC 2000),
- Department of Environment and Conservation (DEC): Bunding & Spill Management. Insert to the Environment Protection Manual for Authorised Officers - Technical section "Bu" November 1997,
- Managing Urban Stormwater: Soils and Construction. Landcom, (4th Edition) March 2004 (reprinted 2006) Volume 1, and NSW Department of Environment, Climate Change and Water, 2008. Volume 2D, (commonly referred to as the "Blue Book").
- Fairfull, S. and Witheridge, G. (2003) Why do Fish Need to Cross the Road? Fish Passage Requirements for Waterway Crossings. NSW Fisheries,
- NSW Fisheries, November 2003. Fishnote – Policy and Guidelines for Fish Friendly Waterway Crossings (Ref: NSWF – 1181),
- RMS Dewatering Guideline (2011),
- RMS Management of Wastes on Roads and Maritime Services Land (2014),
- Approved Methods for the Sampling and Analysis of Water Pollutants in NSW (2004),
- RTA's Code of Practice for Water Management – Road Development and Management (1999)
- Guidelines for the Management of Acid Sulphate materials: Acid Sulphate Soils, Acid Sulphate Rock and Monosulphidic Black Ooze (RTA 2005),
- RMS Environment Direction Management of Tannins from Vegetation Mulch (2012),
- RMS Stockpile Site Management Guideline (2011),
- Environmental Best Management Practice Guideline for Concreting Contractors, DEC (2004), and
- Sydney Harbour Water Quality Improvement Plan (Sydney Metropolitan Catchment Management Authority (SMCMA) 2010).

3.2. Minister’s Conditions of Approval

The CoAs relevant to this Plan are listed in Table 2 below. A cross reference is also included to indicate where the condition is addressed in this Plan or other Project management documents. Specific CoA relevant to soil and surface water management for the Project are included within Annexure A.

Table 2 Conditions of Approval relevant to this Plan

CoA No.	Condition Requirements		Document Reference	How Addressed			
C4(e)	The following CEMP Sub-plans must be prepared in consultation with the relevant authorities identified for each CEMP Sub-plan and be consistent with the CEMP referred to in the EIS.		Section 3.4	This Soil and Surface Water Management Sub-plan has been prepared in accordance with this condition and describes how JHCPB propose to manage soil and surface water during construction of the Project. This Plan was provided to DoI Water / Natural Resources Access Regulator (NRAR) (formerly DPI Water), Office of Environment and Heritage (OEH), Environment Protection Authority (EPA), Sydney Water, City of Sydney Council and Inner West Council for consultation.			
		<table border="1"> <thead> <tr> <th></th> <th>Required CEMP Sub-plan</th> <th>Relevant authority(s) and council(s) to be consulted for each CEMP and Sub-plan</th> </tr> </thead> <tbody> <tr> <td>e)</td> <td>Soil and surface water</td> <td>DPI Water; OEH; EPA; Sydney Water; and relevant council(s)</td> </tr> </tbody> </table>				Required CEMP Sub-plan	Relevant authority(s) and council(s) to be consulted for each CEMP and Sub-plan
	Required CEMP Sub-plan	Relevant authority(s) and council(s) to be consulted for each CEMP and Sub-plan					
e)	Soil and surface water	DPI Water; OEH; EPA; Sydney Water; and relevant council(s)					
C5	The CEMP Sub-plans must state how:						
	(a) the environmental performance outcomes identified in the documents listed in condition A1 as modified by these conditions will be achieved;		Section 2.3 Table 1	This plan was prepared in accordance with the environmental performance outcomes identified in the documents listed in condition A1 and is evidenced primarily in Section 2.3 and Table 1.			
	(b) the mitigation measures identified in the documents listed in condition A1 as modified by these conditions will be implemented;		Section 6 Table 11	The implementation of soil and surface water management and mitigation measures identified in the documents listed in condition A1 are listed in Table 11.			
	(c) the relevant terms of this approval will be complied with; and		Section 3.2 Table 2 Annexure A	Details regarding how JHCPB propose to comply with the relevant terms of approval are listed in this Table and in Annexure A.			
	(d) issues requiring management during construction (including cumulative impacts), as identified through ongoing environmental risk analysis, will be managed.		Section 5.2 Table 11 Environmental Risk Assessment Workshop (Section 3.2.1 of CEMP)	Soil and surface water management issues requiring management during construction of the Project have been identified through the documents listed in Condition A1 and Environmental Risk Assessment Workshop. These issues including cumulative impacts have been detailed in Section 5.2 of this plan and Annexure A2 of the CEMP. Environmental risk analysis will be ongoing and regularly reviewed in accordance with Section 3.9 to Section 3.13 of the CEMP to ensure effective management of soil and surface			

CoA No.	Condition Requirements	Document Reference	How Addressed						
			water. Mitigation and management measures for these issues are listed in Table 11.						
C6	The CEMP Sub-plans must be endorsed by the ER and then submitted to the Secretary for approval no later than one (1) month prior to the commencement of the construction activities to which they apply.	Refer to Section 2.2 of the CEMP	This Soil and Surface Water Management Sub-plan has been endorsed by the ER (20/05/2019). The Soil and Surface Water Management Sub-plan will be submitted to DPE for approval no later than one month prior to the commencement of construction activities.						
C7	Any of the CEMP Sub-plans may be submitted to the Secretary along with, or subsequent to, the submission of the CEMP.	Refer to Section 2.2 of the CEMP	This Soil and Surface Water Management Sub-plan will be submitted for approval to DPE prior to the final submission of the CEMP.						
C8	Construction must not commence until the CEMP and all CEMP Sub-plans have been approved by the Secretary. The CEMP and CEMP Sub-plans, as approved by the Secretary, including any minor amendments approved by the ER, must be implemented for the duration of construction. Where the CSSI is being staged, construction of that stage is not to commence until the relevant CEMP and CEMP sub-plans have been endorsed by the ER and approved by the Secretary.	Refer to Section 2.2 of the CEMP	Construction will not commence until the CEMP and all CEMP Sub-plans have been approved by DPE. The CEMP and relevant Sub-plans will be implemented for the duration of construction.						
C9(a)	<p>The following Construction Monitoring Programs must be prepared in consultation with the relevant authorities identified for each Construction Monitoring Program to compare actual performance of construction of the CSSI against predicted performance.</p> <table border="1"> <thead> <tr> <th></th> <th>Required Construction Monitoring Programs</th> <th>Relevant authority(s) and council(s) to be consulted for each Construction Monitoring Program</th> </tr> </thead> <tbody> <tr> <td>(a)</td> <td>Surface Water Monitoring Program</td> <td>DPI Water, Sydney Water and relevant council(s)</td> </tr> </tbody> </table>		Required Construction Monitoring Programs	Relevant authority(s) and council(s) to be consulted for each Construction Monitoring Program	(a)	Surface Water Monitoring Program	DPI Water, Sydney Water and relevant council(s)	Section 2.3 of the SWQMP	The Surface Water Quality Monitoring Program has been prepared in accordance with this condition and describes how JHCPB propose to monitor surface water quality during construction of the Project. The monitoring program will be provided to Dol Water / NRAR (formerly DPI Water), Sydney Water and City of Sydney Council and Inner West Council for consultation.
	Required Construction Monitoring Programs	Relevant authority(s) and council(s) to be consulted for each Construction Monitoring Program							
(a)	Surface Water Monitoring Program	DPI Water, Sydney Water and relevant council(s)							
C10	Each Construction Monitoring Program must provide: (a) details of baseline data available; (b) details of baseline data to be obtained and when;	Section 3.1 of the SWQMP	The Surface Water Quality Monitoring Program includes details of available baseline water monitoring data, along with details of data to be collected during construction.						
	(c) details of all monitoring of the Project to be undertaken; (d) the parameters of the Project to be monitored; (e) the frequency of monitoring to be undertaken; (f) the location of monitoring;	Section 3.2 of the SWQMP	The details of monitoring to be undertaken by the Project, the parameters to be monitored, the frequency of monitoring and the identification of monitoring locations are described in Section 3.2 of the Surface Water Quality Monitoring Program.						

CoA No.	Condition Requirements	Document Reference	How Addressed
	(g) the reporting of monitoring and analysis results against relevant criteria; (h) details of the methods that will be used to analyse the monitoring data;	Section 3.2.3 of the SWQMP	Section 3.2.3 of the Surface Water Quality Monitoring Program details the reporting of monitoring and analysis against relevant criteria as well as the methods that will be used to analyse the monitoring data.
	(i) procedures to identify and implement additional mitigation measures where results of monitoring are unsatisfactory; and	Section 5.3 of the SWQMP	Procedures to identify and implement additional mitigation measures where results of monitoring are outside of adopted triggers are presented in Section 5.3 of the Surface Water Quality Monitoring Program.
	(j) any consultation to be undertaken in relation to the monitoring programs.	Section 2.3 of the SWQMP	Section 2.3 of the Surface Water Quality Monitoring Program details the consultation undertaken during the development of the monitoring program and also the ongoing consultation identified during construction.
C13	The Construction Monitoring Programs must be developed in consultation with the relevant authorities as identified in Condition C9.	Section 2.3 of the SWQMP	The Surface Water Quality Monitoring Program has been prepared in accordance with this condition and describes how JHCPB propose to monitor surface water quality during construction of the Project. The monitoring program will be provided to DoI Water / NRAR (formerly DPI Water), Sydney Water, City of Sydney Council and Inner West Council for consultation.
C14	The Construction Monitoring Programs must be endorsed by the ER and then submitted to the Secretary for approval at least one (1) month prior to commencement of construction.	Section 1.3 of the SWQMP	The Surface Water Quality Monitoring Program (Revision 02) will be endorsed by the ER. The Surface Water Quality Monitoring Program will be submitted to DPE as part of the Soil and Surface Water Management Plan, for approval no later than one month prior to the commencement of construction activities.
C15	Construction must not commence until the Secretary has approved all of the required Construction Monitoring Programs relevant to that activity and all the necessary baseline data for the required monitoring programs has been collected, to which the CEMP relates.	Section 1.3 of the SWQMP	Construction will not commence until the CEMP and Sub-plans, including relevant construction monitoring programs have been approved by DPE, as detailed in Section 1.3 of the Surface Water Quality Monitoring Program.
C16	The Construction Monitoring Programs, as approved by the Secretary, including any minor amendments approved by the ER, must be implemented for the duration of construction and for any longer period set out in the monitoring program or specified by the Secretary, whichever is the greater.	Section 1.3 of the SWQMP	The Surface Water Quality Monitoring Program will be implemented for the duration of construction as detailed in Section 1.3 of the Surface Water Quality Monitoring Program.

CoA No.	Condition Requirements	Document Reference	How Addressed
C17	The results of the Construction Monitoring Programs must be submitted to the Secretary, and relevant regulatory authorities, for information in the form of a Construction Monitoring Report at the frequency identified in the relevant Construction Monitoring Program.	Section 5.5 of the SWQMP	Section 5.5 of the Surface Water Quality Monitoring Program details the reporting requirements and the frequency required for this reporting.

3.3. Revised Environmental Management Measures

Refer to Annexure A for all REMMs relevant to the development of this Plan, including details of where and how each is addressed.

3.4. Consultation

This Plan was provided to DoI Water (formerly DPI Water), NSW Office of Environment and Heritage (OEH), EPA, Sydney Water, City of Sydney Council, and Inner West Council in accordance with CoA C4(e). Refer to Section 2 of the CEMP for consultation requirements relating to the CEMP and all Sub-plans.

Table 3 details a summary of the consultation undertaken for this Plan and the key issues identified by the relevant stakeholders.

Table 3 Summary of consultation for development of the SSWMP and the Soil and Surface Water Quality Monitoring Program

Agency	Contact with agency	Response received	Key issues	Where addressed
Soil and Surface Water Management Plan				
City of Sydney	Via email from the Project: <ul style="list-style-type: none"> ▪ 05/04/19 – JHCPB submitted Plan and Program and request comments back 19/04/19. ▪ 17/04/19 – JHCPB sent reminder that comments due 19/04/19 ▪ 23/04/19 – JHCPB explained no comments meant that documents would be submitted to DPE. Via phone call from the Project: <ul style="list-style-type: none"> ▪ 12/06/19. 	Via telephone and email to the Project: <ul style="list-style-type: none"> ▪ 12/06/2019- CoS confirmed they had no comments on the documents. 	-	-
Environmental Protection Authority (EPA)	Via email from the Project: <ul style="list-style-type: none"> ▪ 08/04/2019 	Via email to the Project: <ul style="list-style-type: none"> ▪ 09/04/2019 – EPA advised it's not policy to review management plans. Expectations will be in EPL when issued. 	-	-
Inner West Council (IWC)	Via email from the Project: <ul style="list-style-type: none"> ▪ 05/04/19 – JHCPB submitted Plan and Program, requesting comments by 19/04/2019. ▪ 17/04/19 – JHCPB sent reminder that comments due 19/04/2019 ▪ 	Via email to the Project: <ul style="list-style-type: none"> ▪ 05/04/19 – IWC confirmed receipt of email. ▪ 18/04/2019 – IWC provided comments. 	<ul style="list-style-type: none"> ▪ Management of contaminants ▪ Inclusion of Council water quality guidelines and standards ▪ Operational aspects ▪ Pollution prevention ▪ Runoff 	<ul style="list-style-type: none"> ▪ Section 6: Table 11 MM SSWM21 - MM SSWM28 ▪ Section 3 ▪ Future Plan ▪ Section 6: Table 11 ▪ Section 6: Table 11 MM SSWM9

Agency	Contact with agency	Response received	Key issues	Where addressed
Port of Authority of New South Wales	Via email from the Project: <ul style="list-style-type: none"> ▪ 05/04/19 – JHCPB submitted Plan and Program and requested comments back by 19/04/19. 	Via email to the Project: <ul style="list-style-type: none"> ▪ 17/04/19 – Port Authority provided comments on the documents. 	<ul style="list-style-type: none"> ▪ Controls for soil contamination and water quality impacts ▪ Inclusion of ESCPs in Plan ▪ Relevant contamination reports to be provided to Ports ▪ Contamination in C7 site 	<ul style="list-style-type: none"> ▪ Table 11 ▪ Annexure D ▪ Contamination Reports (Phase 1 and 2) ▪ Contamination Reports (Phase 1 and 2), CLMP
Sydney Water	Via email from the Project: <ul style="list-style-type: none"> ▪ 05/04/19 – JHCPB submitted Plan and Program, requesting comments by 19/04/19. ▪ 17/04/19 – JHCPB sent reminder that comments due by 19/04/19. ▪ 23/04/19 – JHCPB explained no comments meant that Plan and Program would be submitted to DPE. ▪ 06/05/2019 – JHCPB reminder that no comments received, and to submit any ASAP. 	Via email to the Project: <ul style="list-style-type: none"> ▪ 11/04/19 – Sydney Water requested more time to review the documents. ▪ 06/05/2019 – Sydney Water confirmed that they had no comments on the documents. 	-	-

Agency	Contact with agency	Response received	Key issues	Where addressed
DPI Water (Dol Water)	<p>Via email from the Project:</p> <ul style="list-style-type: none"> ▪ 05/04/19 – JHCPB submitted Plan and Program, requesting comments by 19/04/19. ▪ 17/04/19 – JHCPB sent reminder that comments due by 19/04/19. ▪ 23/04/19 – JHCPB explained no comments meant that Plan and Program would be submitted to DPE. ▪ 06/05/2019 – JHCPB reminder that no comments received, and to submit any ASAP. ▪ 1/7/19 – JHCPB email following phone discussion on 28/6/19 committing to addressing comments when received, outlining target construction date and providing a current revision of the Plan. <p>Via phone call from the Project:</p> <ul style="list-style-type: none"> ▪ 20/06/19 – JHCPB phone call trying to contact assigned officer, reminding Dol that comments should be submitted ASAP. ▪ 25/06/19 – JHCPB to NRAR contact line attempting to reach officer. Message left. ▪ 26/6/19 – As above ▪ 28/6/19 – Discussion with officer. Review has not commenced due to competing priorities. 	<p>Via email to the Project:</p> <ul style="list-style-type: none"> ▪ 24/04/19 – DPI advised that officer has been assigned to submission and is back from leave on 29/04/19. <p>Note: meeting has been organised for 10/07/19 to attempt to prompt feedback on documents.</p>	-	-

Agency	Contact with agency	Response received	Key issues	Where addressed
Soil and Surface Water Quality Monitoring Program				
Sydney Water	Refer above to consultation on the SSWMP.	-	-	-
City of Sydney	Refer above to consultation on the SSWMP.	-	-	-
DPI Water	Refer above to consultation on the SSWMP.	-	-	-
Inner West Council (IWC)	Refer above to consultation on the SSWMP.	-	-	-
Office of Environment and Heritage (OEH)	Refer above to consultation on the SSWMP.	-	-	-
Environment Protection Authority (EPA)	Refer above to consultation on the SSWMP.	-	-	-
Port Authority of New South Wales	Refer above to consultation on the SSWMP.	-	-	-

Specific consultation will be undertaken with Sydney Water regarding the timing of the works at Whites Creek Stormwater Channel and compatibility of the proposed design and Sydney Water’s naturalisation works. Consultation will occur on the final design and location of the works in accordance with CoA E161.

Ongoing consultation with relevant councils and other stakeholders, including any unique local receivers, will be undertaken for particular issues pertaining to the Project’s impact on soil and surface water as required by CoA C4(e) and C9(a). Community feedback and complaints relating to soil and surface water will be managed in accordance with the Communication Strategy and Complaints Management System.

4. Existing Environment

4.1. Topography and soil characteristics

4.1.1. Topography

The landform of the Project area is relatively flat and low-lying, with gentle undulating hills ranging to about 30 metres above Australian Height Datum (AHD).

4.1.2. Soil landscapes

According to the EIS (AECOM, 2017), the Project is located in the Sydney Basin and is predominantly underlain by Ashfield Shale and Hawkesbury Sandstone, which outcrop in topographically high areas. In lower-lying areas such as Rozelle Bay and White Bay, the bedrock is overlain by fill and alluvium.

Soils within the Project area have been significantly disturbed as a result of past urban development. Soil Landscape mapping (Chapman and Murphy, 1989) identified four soil landscapes within the Project footprint area, as described in Table 4. Mitigation measures are identified in Table 7.

Table 4 Soil landscape descriptions within Project area

Soil landscape name	Occurrence / characteristics	Erosion potential	Mitigation measures
GyMEA	<ul style="list-style-type: none"> Occurs extensively along foreshores of Sydney Harbour and the Parramatta River Localised steep slopes Very low soil fertility Shallow, highly permeable, acidic soils 	<ul style="list-style-type: none"> High soil erosion hazard 	<p>In addition to the following mitigation measures for high soil erosion hazard areas, planning will have a focus on erosion prevention, by minimising exposed ground, (use of mulches and ground cover and staging hardstand removal) in addition to sediment control:</p> <ul style="list-style-type: none"> MM SSWM5 - MM SSWM7 MM SSWM9 MM SSWM11 - MM SSWM15 MM SSWM21
Blacktown	<ul style="list-style-type: none"> Occurs on Cumberland Lowlands between the Georges and Parramatta Rivers Moderately reactive, highly plastic subsoil Low soil fertility Poor soil drainage 	<ul style="list-style-type: none"> Moderate erodibility 	<ul style="list-style-type: none">
Hawkesbury	<ul style="list-style-type: none"> Steep slopes Rock outcrop Shallow, stony, highly permeable, acidic soils Low soil fertility. 	<ul style="list-style-type: none"> Extreme soil erosion hazard 	<ul style="list-style-type: none"> MM SSWM5 - MM SSWM7 MM SSWM9 MM SSWM11 - MM SSWM15 MM SSWM21
Disturbed terrain	<ul style="list-style-type: none"> Occurs in landscapes disturbed by human activity, including complete disturbance, removal or burial of soil. 	<ul style="list-style-type: none"> Variable soil constraints, including potential contamination 	<ul style="list-style-type: none"> MM SSWM5 - MM SSWM7 MM SSWM9 MM SSWM21 - MM SSWM28

4.1.3. Soil Salinity

The Project alignment does not affect land known to be naturally saline, based on a review of the Salinity Potential in Western Sydney Map (NSW Department of Infrastructure, Planning and Natural Resources 2002, in AECOM 2017).

4.1.4. Acid sulfate soils

Acid sulfate soils (ASS) are naturally occurring soils that contain iron sulfides which, when exposed to the air, can oxidise to form sulfuric acid and can pose a risk to the environment if not appropriately managed. Potential acid sulfate soils (PASS) are generally waterlogged soils, rich in pyrite that have not been oxidised. Disturbance of ASS and/or PASS can result in adverse impacts on surface and groundwater quality, flora and fauna, and degradation of habitats.

In NSW, land is classified based on the likelihood of acid sulfate soils being present in particular areas and at certain depths. There are five classifications (Department of Land and Water Conservation, 1998):

- Class 1: Acid sulfate soils are likely to be found on and below the natural ground surface. Any works would trigger the requirement for assessment and may require management,
- Class 2: Acid sulfate soils are likely to be found below the natural ground surface. Any works beneath the natural ground surface, or works which are likely to lower the water table, would trigger the requirement for assessment and may require management,
- Class 3: Acid sulfate soils are likely to be found more than 1m below the natural ground surface. Any works that extend beyond one metre below the natural ground surface, or works which are likely to lower water table beyond one metre below the natural ground surface, would trigger the requirement for assessment and may require management,
- Class 4: Acid sulfate soils are likely to be found more than 2m below the natural ground surface. Any works that extend beyond 2m below the natural ground surface, or works which are likely to lower the water table beyond 2m below the natural ground surface, would trigger the requirement for assessment and may require management, and
- Class 5: Acid sulfate soils are not typically found in Class 5 areas. Areas classified as Class 5 are located within 500m on adjacent Class 1, 2, 3 or 4 land. Works in a Class 5 area that are likely to lower the water table below 1m AHD on adjacent Class 1, 2, 3 or 4 land would trigger the requirement for assessment and may require management.

The majority of the Project occurs on lands with a low risk in terms of the occurrence of ASS or PASS (AECOM, 2017), generally mapped as Class 5.

Areas of the Project corridor where ASS or PASS may occur are noted in Table 4 (AECOM, 2017), Figure 1 and Figure 2.

Management and mitigation measures are outlined in Section 5.2.2 and Section 6.

Table 5 Locations of ASS or PASS within Project corridor

Construction Area	Class of ASS Present	Lines of Evidence	Management and mitigation measures
C5 Rozelle Rail Yards (RRY) (Rozelle Civil and Tunnel Site)	Class 1, 2 & 5	Potential acid sulfate soils (PASS) have been detected within the alluvial sediments across the RRY.	Section 6 Table 11: <ul style="list-style-type: none"> • MM SSWM21 • MM SSWM22 • MM SSWM23 • MM SSWM24 • MM SSWM28
C6 The Crescent Civil Site	Class 1 & 3	<ul style="list-style-type: none"> • Class 1 mapped land is located within proximity to the site; and • Based on analytical results PASS/actual ASS are present. 	Section 6 Table 11: <ul style="list-style-type: none"> • MM SSWM21 • MM SSWM22 • MM SSWM23 • MM SSWM24 • MM SSWM28
C7 Victoria Road Civil Site at Rozelle	Class 5	Based on the information provided by DP&E, the site is within land mapped as Soil Class 5 (no known occurrence of acid sulfate soils) and is adjacent to Class 2 mapped land.	Section 6 Table 11: <ul style="list-style-type: none"> • MM SSWM21 • MM SSWM24 • MM SSWM28
C8 – Iron Cove Link Civil Site	Class 2 & 5	A small area of the northeast corner of the site is mapped as Soil class 1 and the western half is mapped as Soil Class 2.	Section 6 Table 11: <ul style="list-style-type: none"> • MM SSWM21 • MM SSWM22 • MM SSWM23 • MM SSWM24 • MM SSWM28

Figure 1 Locations of PASS within the Project corridor

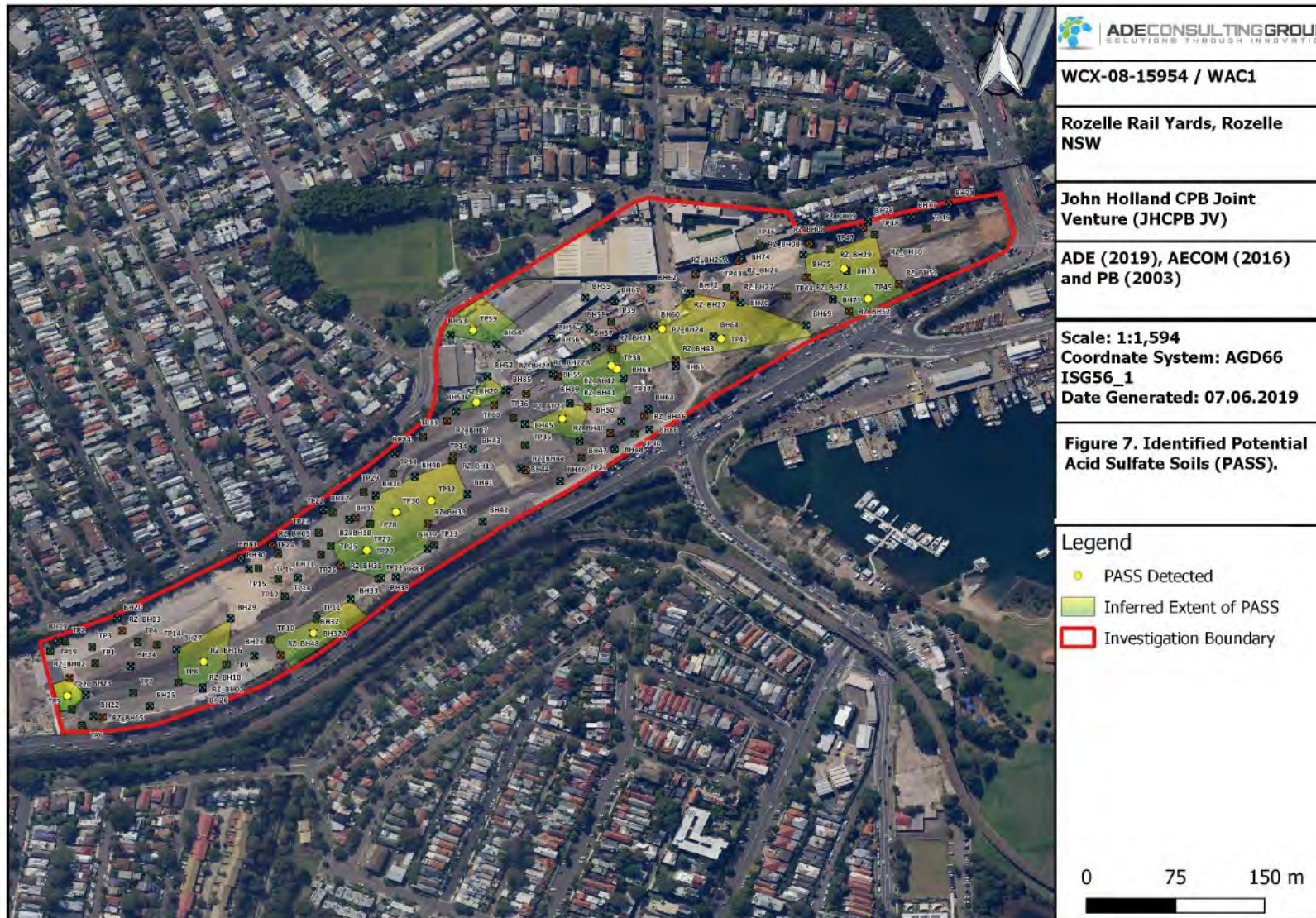





	
WCX-08-15954 / WAC1	
Rozelle Rail Yards, Rozelle NSW	
John Holland CPB Joint Venture (JHCPB JV)	
ADE (2019), AECOM (2016) and PB (2003)	
Scale: 1:1,594 Coordinate System: AGD66 ISG56_1 Date Generated: 07.06.2019	
Figure 7. Identified Potential Acid Sulfate Soils (PASS).	
Legend	
	PASS Detected
	Inferred Extent of PASS
	Investigation Boundary
	

Figure 2 Acid sulfate soil map



Location of the study area is outlined in red. Locations of acid sulphate soils is shown in the red shaded areas. Acid Sulphate Soil Map accessed from the NSW Government eSpade website (30/05/2019)

4.2. Surface water

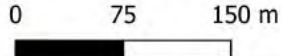
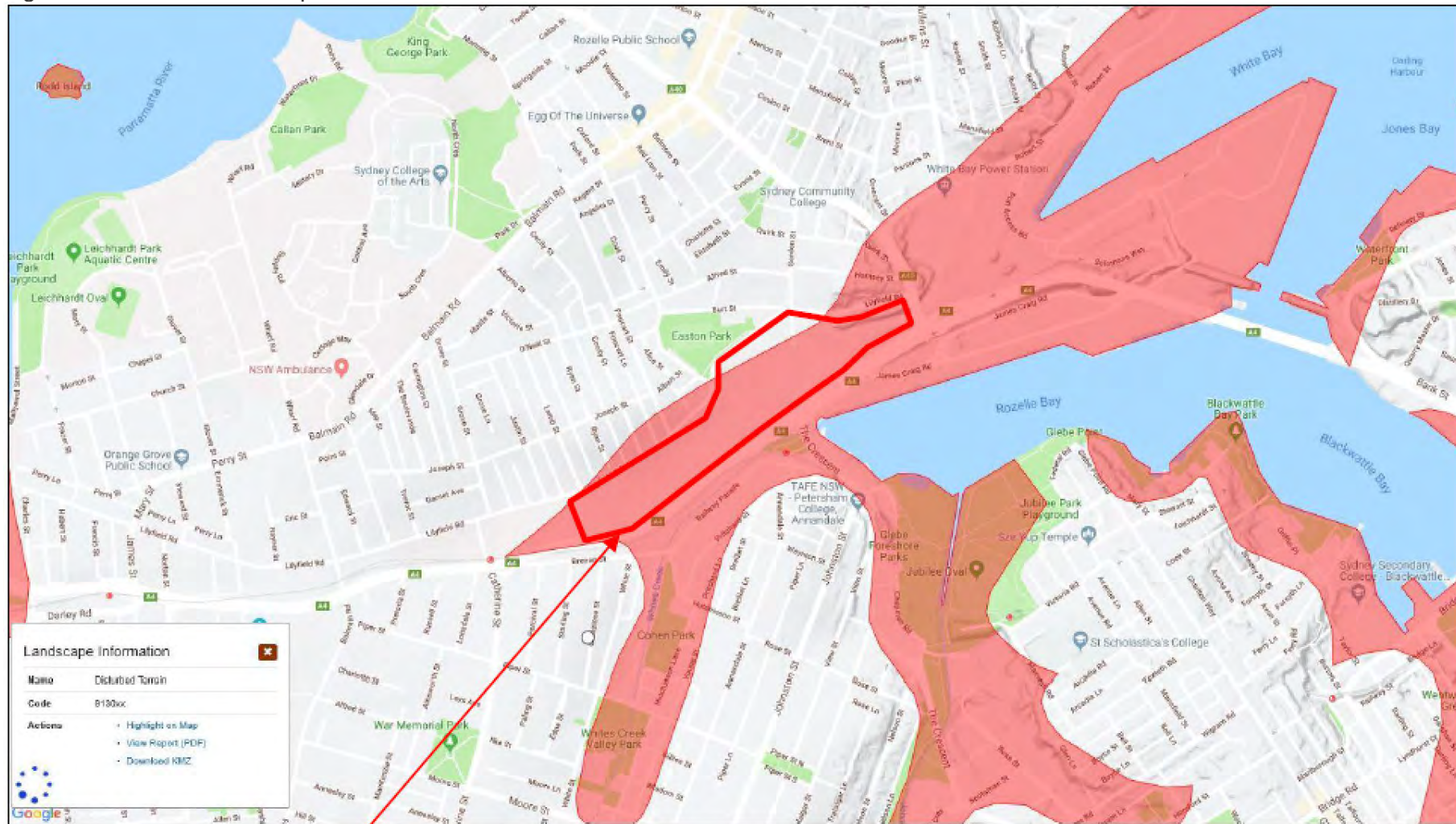
4.2.1. Catchments

The Project is located wholly within the Sydney Harbour and Parramatta River catchment. Table 6 and Figure 3 outline the sub-catchments which form part of the larger Sydney Harbour and Parramatta River catchments near to the Project.

Table 6 Sub-catchments relevant to the Project

Sub-catchment	Description	Project interaction
Whites Creek	Whites Creek is a brick and concrete-lined channel that flows through the suburbs of Leichhardt and Marrickville and discharges into Rozelle Bay. The Whites Creek catchment is heavily urbanised and comprises an area of around 262ha. Whites Creek at The Crescent is a 1st order stream.	Rozelle Interchange, surrounding roads and associated construction infrastructure and ancillary sites.
Easton Park Drain	The Easton Park drain runs between Denison Street (adjacent to Easton Park) and Rozelle Bay at Rozelle and conveys runoff from a heavily urbanised catchment of around 55ha. Easton Park drain is a 1st order stream.	Rozelle Interchange and associated construction infrastructure and ancillary sites.
Rozelle Bay	The Rozelle Bay catchment is highly urbanised and comprises a total area of around 857ha. Rozelle Bay is located between the suburbs of Glebe, Annandale, Lilyfield and Rozelle with flow inputs from Whites Creek, Johnstons Creek and Easton Park drain.	Rozelle Interchange, surrounding roads and associated construction infrastructure and ancillary sites.
White Bay	The White Bay catchment is highly urbanised and comprises a total area of around 163ha.	Runoff from Victoria Road.
Iron Cove	The Iron Cove catchment is a bay within the Parramatta River estuary. It is highly urbanised and comprises a total area of around two hectares. Iron Cove is a 2nd order stream and has been mapped as Key Fish Habitat.	Iron Cove Link civil site, surface works and bioretention system construction.

Sydney Water has identified future upgrades or naturalisation of Whites Creek, plus stormwater and drainage upgrades are proposed at Easton Park in Rozelle (AECOM, 2017).

Table 7 Water quality summary

Sub-catchment	Sampling locations	Summary description
Whites Creek	SW02 (AECOM, 2017) Samples collected by The University of Sydney on behalf of UrbanGrowth NSW within a tidally influenced location (at SW02) as part of The Bays Precinct transformation Project between June and September 2016.	Elevated concentrations of heavy metals (chromium, copper, lead and zinc), phosphorus, nitrogen, nitrate and oxides of nitrogen were recorded. On some occasions the pH was outside guideline levels and the turbidity exceeds guideline levels (ANZECC, 2000).
Easton Park Drain	SW07 (AECOM, 2017).	Elevated concentrations of heavy metals (copper, lead, and zinc) and nutrients (nitrogen phosphorus and nitrate) were recorded. On some occasions, the pH was outside guideline levels and the turbidity exceeded guideline levels (ANZECC, 2000).
Rozelle Bay	SW01 (AECOM, 2017). Samples collected by The University of Sydney on behalf of UrbanGrowth NSW at BW1 as part of The Bays Precinct transformation Project between June and September 2016.	Elevated concentrations of heavy metals (copper, chromium, lead and zinc), nitrogen, phosphorous, nitrate, oxides of nitrogen, ammonia and chlorophyll have been recorded. On some occasions the pH is outside guideline levels and the turbidity exceeds guideline levels (ANZECC, 2000).
White Bay	Samples collected by The University of Sydney on behalf of UrbanGrowth NSW at BW2 as part of The Bays Precinct transformation Project between June and September 2016.	Elevated concentrations of metals (copper and zinc), nitrogen, nitrate and phosphorous have been recorded. Turbidity also exceeds the guideline values (ANZECC, 2000).
Iron Cove	SW11 and SW12 (AECOM, 2017)	Elevated concentrations of metals (copper, chromium, lead, mercury and zinc), nitrogen, nitrate and phosphorous have been recorded. Turbidity exceeds guideline values. The pH was outside guideline levels on occasions (ANZECC, 2000).

4.2.3. Sensitive receiving environments

A sensitive receiving environment is an environment that has high conservation or community value, or that supports ecosystem or human uses of water, and that is particularly sensitive to pollution or degradation of water quality.

The Project has the potential to interact with the following sensitive receiving environments (from AECOM, 2017):

- Iron Cove (water recreation reserve),
- Whites Creek constructed wetland at Whites Creek Valley Park, and
- Fish habitat in Rozelle Bay and White Bay.

Other sensitive receiving environments include waterfront land. As described in Section 3.2.1 of the Blue Book (Landcom 2004), waterfront lands are those vegetated lands immediately next to waterbodies such as rivers, creeks, estuaries, lakes and wetlands. The distance in which waterfront lands occurs away from water bodies varies greatly, depending on factors such as the nature of the waterbody, the local geology and landform. Waterfront lands identified within the Project boundary are featured in Figure 4. Activities to occur within waterfront land include the naturalisation of Whites Creek and activities along The Crescent. Management measures within this area will be carried out in accordance with mitigation measures listed in Section 6. For the purposes of this Plan, waterfront land has replaced riparian land.

Figure 4 Waterfront land near Victoria Road



Note: Waterfront land identified in blue

Figure 5 Waterfront land near the City West Link and The Crescent

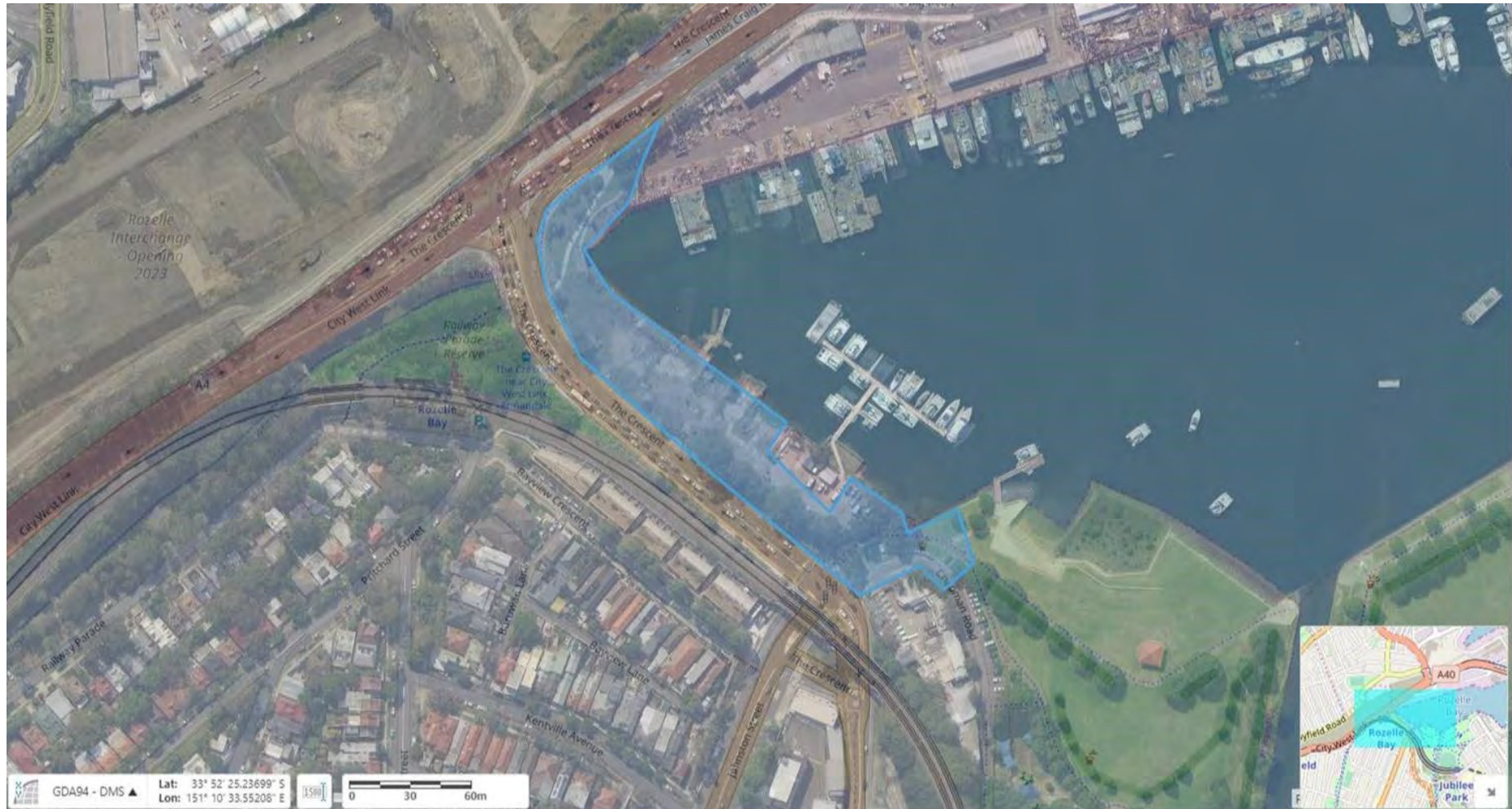

Note: Waterfront land identified in blue

4.3. Rainfall

Climate data was sourced from the Bureau of Meteorology (BOM) website for Observatory Hill station 66062. The weather monitoring station is less than 3km from the Project.

Data is presented in Table 8, showing that temperatures are warm in summer, with mild winters. Rainfall occurs throughout the year with slight summer dominance. Mean annual rainfall is 1,215.7 mm/yr.

Average afternoon wind speeds are sufficient to contribute to potential dust rise, particularly during hot and/or dry conditions.

Table 8 Climate statistics for Observatory Hill (station 66062) from the Bureau of Meteorology

	Jan	Feb	Mar	Apr	May	Jun	July	Aug	Sep	Oct	Nov	Dec
Mean max temp (°C)	26.0	25.8	24.8	22.5	19.5	17.0	16.4	17.9	20.1	22.2	23.7	25.2
Mean min temp (°C)	18.7	18.8	17.6	14.7	11.6	9.3	8.1	9.0	11.1	13.6	15.7	17.5
Mean rainfall (mm)	102.2	117.6	130.9	128.5	118.6	133.2	96.6	81.1	68.4	76.4	83.8	77.6
Avg no of days >1mm rain	8.6	9.0	9.8	9.0	8.6	8.7	7.5	7.2	7.2	7.9	8.4	8.0
Mean 9am wind speed (kmh)	8.6	8.2	7.9	8.8	10.5	11.9	13.1	13.3	12.4	12.2	11.0	9.8
Mean 3pm wind speed (kmh)	17.9	16.8	15.2	13.8	12.7	13.6	15.3	17.6	18.3	19.1	19.4	19.5

4.4. Rainfall erosivity factor

The rainfall erosivity factor is a measure of the ability of rainfall to cause erosion (referred to as “R” in the Revised Universal Soil Loss Equation RUSLE). The rainfall erosivity factor is used to help determine the soil loss in tonnes per hectare over one year and is used in calculations when sizing construction sediment basins.

For the purpose of designing sediment basins and managing erosion the Rainfall Erosivity Factor erosion index (EI) of 3,480 EI has been selected, based on the Rainfall Erosivity maps in the Blue Book. Specific R values for specific sites will be listed in the site-specific ESCPs.

The risk of rainfall erosion will slightly higher during summer months; dry weather combined with high winds or high intensity storms can lead to erosion. Increased use of certain controls such as soil binders and crusting would be required in addition to considering how activities are scheduled. Storm intensity and frequency would be considered when planning controls (Table 9 below). Details on how erosion risk will be managed is outlined in Section 6.

Table 9 Monthly % and annual rainfall erosivity (R-factor) values for Rozelle

Monthly % and annual rainfall erosivity (R – factor) values													
	Dec	Jan	Feb	Mar	Apr	Mar	Jun	July	Aug	Sep	Oct	Nov	Year
%	12	15	16	11	9	5	4	4	4	5	7	8	100
R - Value	418	522	557	383	313	174	139	139	139	174	244	278	3,480

4.5. Flooding

The EIS (AECOM, 2017) identified the potential flood risk for the various drainage lines that the Project would intersect. Minimal impact was identified for the Iron Cove Link. However, the old Rozelle Rail Yards area was identified as a potential storage area for floodwater overtopping the

Easton Park Drain. The site of the proposed Rozelle Interchange is classed as a flood control lot in the Leichhardt Development Control Plan (Leichhardt Council 2013).

As the Rozelle Rail Yards site is within a topographically low area, it receives runoff from relatively steep, contributing catchments to the north and west. This, combined with the limited capacity of the local drainage network, means that the site functions as a flow path for overland flow and provides temporary floodwater storage, limited by outflows in the existing drainage network.

AECOM (2017) identified that flow velocities across the site during flood events are generally low. For example, in the 100-year ARI event, peak flow velocities are less than 0.5 metres per second across most of the site, and typically less than 0.2 metres per second.

Flood hazards according to the Floodplain Development Manual (NSW Government 2005) were identified by AECOM (2017) for the 100-year ARI. The Easton Park Drain and Whites Creek, as well as their overbank areas (including sections of Railway Parade), are considered high flood hazard zones. The Rozelle Rail Yards site is generally a low flood hazard area, except for a small area near Victoria Road.

The Project will design and install erosion and sediment control in accordance with the Blue Book (Chapter 5 Erosion Control: Management of Water. Landcom, 2004 and DECC, 2008). This includes the development of a flood contingency plan which will be developed for areas within the five year flood ARI. Figure 5 notes the Project's flood contingency plan for events that would affect the sites.

Figure 6 Flood contingency plan

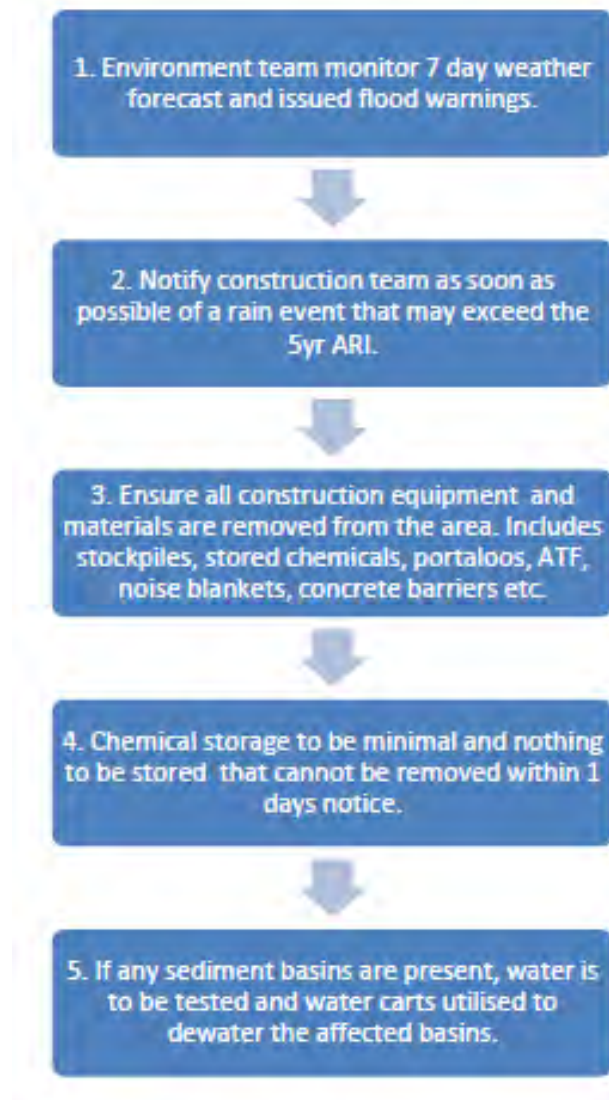

5. Environmental aspects and impacts

5.1. Construction activities

Key construction activities that could result in adverse impacts to soils and surface water include:

- Vegetation clearing and topsoil stripping,
- Bulk earthworks,
- Construction and use of site accesses,
- Culvert and drainage works,
- Material stockpiling including the treatment of acid sulfate soil,
- Diaphragm wall construction for shafts,
- Paving activities,
- Water use / extraction,
- WTP establishment and operation, and
- Operations in the compounds including fuel and chemical storage, refuelling and chemical handling.

5.2. Impacts

5.2.1. Overview

The potential for impacts on soil and water will depend on a number of factors. Primarily impacts will be dependent on the nature, extent and magnitude of construction activities and their interaction with the natural environment. Potential impacts attributable to the Project, discussed in detail below, include but are not limited to:

- Changes in surface water quality from:
 - › Spills and incidents,
 - › Discharges of tunnel wastewater,
 - › Mobilisation of sediments and pollutants during surface works,
- Impacts to soils:
 - › Erosion and sedimentation,
 - › Soil salinity,
 - › Acid sulfate soils, and
 - › Scour and changes to channel geomorphology
 - › Topsoil removal; of particular relevance at King Georges Park Rozelle where topsoil is present
 - › Soil compaction and soil structure decline; of particular relevance at King Georges Park Rozelle where parkland will be returned to parkland. The remainder of the Project will have final land uses as roadway and new created parkland with imported fill and growth medium layers,
 - › Impacts from earthworks and construction machinery, such as compaction / loss of air voids and water holding capacity, aggregate breakdown and pulverisation. These impacts are less pronounced in existing roadways, under buildings and brownfield sites.

As noted in the EIS, impacts on soil and water attributable to the Project are anticipated. Relevant aspects and the potential for related impacts have been considered in a risk assessment in Construction Environmental Management Plan (CEMP), Annexure B. Section 6 of this Plan includes a suite of mitigation measures that will be implemented to avoid or minimise impacts.

5.2.2. Soils

Erosion and Sedimentation

Surface construction activities have the potential to result in erosion and sediment migration. Surface disturbance and vegetation removal exposes soils and may weaken surface soil structure

leading to erosion sedimentation and soil slippage within and around waterways and slopes in the Project area, particularly during periods of high wind or rainfall (AECOM 2017). Areas of high erosion potential are at a higher risk of being subject to erosion and sedimentation. These areas and their relevant mitigation measures are identified in Table 3. Management strategies outlined in the site specific ESCP's are developed from the outcomes of the Erosion Hazard Assessment, $RUSLE = R \times K \times LS \times P \times C$:

- R = Rainfall factor
- K = soil erodibility factor
- LS= slope length and gradient factor
- P = Conservation practices
- C= Ground cover.

Risk-based inspections by the Project Soil Conservationist then monitor the performance of these management strategies, which are updated upon advice from the Project Soil Conservationist. For further details on the management strategies, refer to Section 6. The EIS identifies that the tunnel will, over long durations (infrastructure operational life span), draw saline water inland from the adjacent bays and coves. The impact of this will be modelled and assessed in accordance with condition of approval E101 in the hydrological interpretive report. The currently inferred gradient from the shoreline is predicted to be 1:40. As such, long term changes in groundwater salinity are extremely unlikely to affect subject matter within this Plan. Monitoring for salinity is addressed in the Groundwater Monitoring Program.

Uncompacted or unconsolidated materials (such as excavated and stockpiled soils) have the potential to migrate from construction areas during rain (through surface water run-off) causing downstream sedimentation. Sedimentation in natural waterways can result in reduced water quality as well as smothering of vegetation and clogging of channels, impacting the natural flow paths of the waterway.

During construction, soil erosion will be managed in accordance with Managing Urban Stormwater: Soils and Construction Volume 1 (Landcom 2004) and Managing Urban Stormwater: Soils and Construction Volume 2 (NSW Department of Environment and Climate Change 2008a), commonly referred to as the 'Blue Book'.

Erosion and sediment control would be focussed on areas of surface disturbance (i.e. surface road works, construction ancillary facility sites and areas of excavation and vegetation removal). Particular emphasis would be given to areas of surface disturbance near waterways, including at Rozelle Bay, where Whites Creek naturalisation and drainage work and Easton Park drain outfall works would be undertaken. These measures would minimise the potential for sedimentation at Rozelle Bay.

Project Erosion and Sediment Control Plans (ESCPs) will be prepared in accordance with the Blue Book Volumes 1 and 2D (Landcom, 2004 and DECC, 2008) for each specific stage or parcel of work prior to commencing construction in consultation with construction staff. These will be updated as required and will be developed in consultation with the Project's soil conservationist where required.

The ESCP will be prepared by a person with demonstrated skills and experience in preparing the ESCP in accordance with the Blue Book Volumes 1 and 2D (Landcom, 2004 and DECC, 2008).

ESCPs will be signed off by the Site Environment Manager and Site Supervisor (or their representatives) and copies kept on the premise for the duration of the Project

Baseline ESCPs have been included as Annexure D. It is noted however that updates to ESCPs will not result in a review and subsequent update to this Plan. Any updates to ESCPs will be managed through internal document control procedures.

Soil salinity

Construction of the Project has the potential to contribute to soil salinity through soil compaction at areas of surface disturbance, such as the construction of ancillary facility sites, which can restrict groundwater flow and result in a concentrate of salt in one area (AECOM 2017). As outlined in the EIS and Section 4.1.3, soil salinity is not considered a significant concern within the Project footprint.

Acid sulfate soils

Soil testing will be conducted in all civil and tunnel sites prior to disturbance, to confirm the presence of sulfidic soils. Likely areas of acid sulfate soil (ASS) and potential acid sulfate soil (PASS) are identified in Section 4.1.4.

Where actual acid sulfate soils (AASS) have been identified, they will be managed in accordance with the Acid Sulfate Soil Manual (1998). The manual includes procedures for the investigation, handling, treatment and management of such soils. This procedure has been outlined in the Unexpected Contaminated Lands Find Procedure included in Annexure C of this Plan.

Where PASS have been identified, they will be managed in accordance with the Acid Sulfate Soil Manual. The Acid Sulfate Soils Manual refers to field testing parameters (pHF and pHFOX) which may indicate actual PASS. The following testing parameters are considered relevant:

- Field pH measurements:
 - pH readings of pH less than 4, indicate that AASS are likely to be present; and
 - pH readings of pH >4, indicate the absence of AASS, however does not give any indication of the PASS;
- Field peroxide measurements. A positive peroxide test indicating one of more of the following may indicate the presence of PASS:
 - Change in colour of the soil from grey to brown tones;
 - Effervescence;
 - Release of sulfur smelling gases such as sulfur dioxide and hydrogen sulfide
 - A lowering of the soil pH by at least one unit; and
 - A final pH less than 3.0.

The presence of sulfidic soils will be investigated during Phase 1 and Phase 2 soil contamination investigations which include laboratory testing. Remedial Action Plans (RAP) and/or where a RAP is not deemed necessary, a Contamination Management Summary (CLMS) would be prepared for specific locations and detail the remediation requirements for contamination, including sulfidic soils. These documents include detailed information regarding the laboratory testing requirements in order to 'validate' soils.

Regular monitoring of areas where ASS is expected will be undertaken to identify signs of sulfide oxidation. Visual and olfactory cues are:

- Yellow / orange / red staining on upper sediments and surrounding surfaces;
- Rust coloured deposits on plants and on the banks of drains, water bodies and watercourses indicating iron precipitates;
- Waterlogged soils with a hydrogen sulfide, 'rotten egg' smell;
- Area of black ooze (potentially indicating monosulfidic black oozes) typically in drains and low-lying areas;
- Unexplained scalding, degradation or death of surrounding vegetation;

- Unexplained death or disease of aquatic organisms;
- Areas of green-blue water or extremely clear water indicating high concentrations of aluminium; and
- Black to very dark coloured waters indicating de-oxygenation.

5.2.3. Surface Water Quality

Spills and Incidents

Vehicle or plant and equipment leakages or a vehicle crash may cause spills of oils, lubricants, hydraulic fluids and chemicals during the construction of the Project. If there are spills or leakages within the Project footprint, they would have the potential to pollute downstream waterways via the stormwater network.

The risks to surface water as a result of such incidents would be managed through construction management procedures in accordance with the CEMP and in accordance with the measures outlined in Section 6. With the implementation of these measures, the risk of water quality impacts would be low.

Entire sites, such as The Crescent civil site (C6) are within waterfront land. Refuelling and small volume short term chemical storage within 40m of a water way can only be done under an approved EWMS. The EWMS will be approved by RMS releasing a hold point for the document.

- Refuelling will be undertaken in an area designated in the EWMS which shall be at the furthest useable location from the water way.
- The refuelling location will have a spill kit.
- Refuelling or chemical transfer will be undertaken within a portable bund.
- Chemical storage will be limited to containers that can be removed with one days' notice.
- All chemicals will be stored in bunds.

Discharge of tunnel wastewater

Results of baseline groundwater monitoring carried out for the Project (detailed in the GWMP) have been compared to ANZECC (2000) guideline levels (marine and recreational protection levels) to assess the likely water quality of tunnel inflows. Tunnel wastewater, if discharged untreated or poorly treated, has the potential to impact the receiving waterways. There is also potential for reduction in visual amenity and impacts on aquatic species as a result of heavy metal or other toxicants (AECOM 2017).

During construction, groundwater collected in the tunnel will be treated and tested at Rozelle construction WTPs prior to reuse, or discharge to trade waste or receiving waterways (Whites Creek / Rozelle Bay). The discharge criteria for the WTPs are included in the GWMP along with details of water quality testing of the discharge from the WTP.

Mobilisation of sediments and pollutants during surface works

Surface construction activities that may disturb soils and other materials have the potential to impact water quality if not effectively managed.

Table 10 summarises the potential water quality impacts during construction of the Project. The contaminants of concern as a result of the construction are increased turbidity from soil disturbance, and increased pH due to the use of concrete and its products. Management and mitigation measures to prevent the identified potential impacts are provided in Section 6. These potential impacts are regularly encountered on major construction Projects, are well understood, and management measures are well developed and consistently applied to minimise impact during construction (AECOM 2017).

Routine surface water quality monitoring and analysis for appropriate physio-chemical parameters will occur at specific downstream locations during construction (refer Annexure B).

Table 10 Summary of potential construction surface water quality impacts (from the M4-M5 Link EIS)

Item	Activity	Potential impacts
1	Storage and use of potential contaminants or hazardous substances near drainage lines and stormwater systems	<ul style="list-style-type: none"> ▪ Potential for soil contamination from spills or leaks ▪ Potential for pollutants to wash into stormwater systems, then to the receiving environment.
2	Clearing of vegetation and topsoil stripping during site establishment	<ul style="list-style-type: none"> ▪ Potential for sediment-laden runoff to wash offsite into stormwater systems and the receiving environment ▪ Damage to protected vegetation (if relevant) ▪ Disturbance of areas outside the Project footprint ▪ Potential for dust to be blown offsite, impacting neighbours.
3	Earthworks to establish surface sites	<ul style="list-style-type: none"> ▪ Potential for sediment-laden runoff to wash offsite into stormwater systems and the receiving environment ▪ Disturbance of areas outside the Project footprint ▪ Potential for dust to be blown offsite, impacting neighbours.
4	Discharge of water detained onsite following heavy rainfall / localised flooding	<ul style="list-style-type: none"> ▪ Potential for polluted water to be discharged offsite.
5	Stockpiling of spoil and other materials	<ul style="list-style-type: none"> ▪ Potential for sediment-laden runoff to wash offsite into stormwater systems and the receiving environment ▪ Potential for dust to be blown offsite, impacting neighbours.
6	Use of plant and equipment	<ul style="list-style-type: none"> ▪ Potential for spills or leaks of fuels, oils and fluids onto soils or into stormwater systems or waterways ▪ Potential for tracking of sediment onto public roads, leading to traffic safety issues and pollution of stormwater systems and receiving waters.
7	Dewatering of groundwater inflows into tunnels	<ul style="list-style-type: none"> ▪ Potential for polluted water to be accidentally discharged offsite ▪
8	Temporary site facilities – sewer connections and use of portable toilets	<ul style="list-style-type: none"> ▪ Potential for sewer overflows or portable toilets to discharge into stormwater systems and the receiving environment.
9	Loading and transport of materials	<ul style="list-style-type: none"> ▪ Potential for dust impacts during loading and transport. ▪ Potential for tracking of sediment onto public roads, leading to traffic safety issues and pollution of stormwater systems and receiving waters.
10	Construction or modification to stormwater systems	<ul style="list-style-type: none"> ▪ Potential for accidental discharge of sediment-laden runoff into stormwater systems.
11	Tunnelling	<ul style="list-style-type: none"> ▪ Potential for flooding into tunnel portals ▪ Potential for the quality of groundwater flowing into tunnels to be impacted ▪ Potential for drawdown of groundwater tables to impact wetlands or areas of PASS ▪ Potential for drawdown of groundwater tables to impact on bores.

Item	Activity	Potential impacts
12	Concreting and grouting	<ul style="list-style-type: none"> ▪ Potential for water quality impacts on surface and groundwater from concreting and grouting ▪ Potential for spills of excess or waste concrete ▪ Potential for waste concrete to be discharged into stormwater systems.
13	Treatment of groundwater inflows and release to surface water	<ul style="list-style-type: none"> ▪ Potential changes to surface water quality or quantity ▪ Potential impacts on downstream water users.

Scour and channel geomorphology

Stormwater and construction water from the Project, including the WTPs, will be discharged to the existing stormwater system. This stormwater system includes concrete lined drainage pipes, concrete lined creeks and channels. It is therefore anticipated that scouring is not expected to be an issue. Should discharge occur into a potentially erodible area, scour protection will be installed in accordance with the Blue Book (NSW Department of Environment and Climate Change 2008a).

Given the highly urbanised, artificial characteristics of the majority of watercourses, changes to channel geomorphology as a result of discharge to the waterways are considered to be unlikely (AECOM 2017).

6. Environmental control measures

Specific measures and requirements to meet the objectives of this Plan and to address impacts on soil and water are outlined in Table 11.

Table 11 Soil and Water management and mitigation measures

ID	Measure/Requirement	When to implement	Responsibility	Reference	Evidence
General					
MM SSWM1	Environmental incidents where material harm to the environment is caused or threatened will be managed in accordance with the Pollution Incident Response Management Plan (PIRMP) and the Project EPL.	Construction	Environment and Sustainability Manager (or delegate)	Protection of the Environment Operations Act 1997 (POEO Act)	PIRMP Environmental incident report
MM SSWM2	Environmental incidents that do not trigger SWM1 will be managed and reported in accordance with the Project CEMP.	Construction	Environment and Sustainability Manager (or delegate)	CEMP	Environmental incident report
MM SSWM3	Except as may be provided by an EPL, the Project shall be constructed and operated to comply with section 120 of the POEO Act, which prohibits the pollution of waters.	Construction	Environment and Sustainability Manager (or delegate)	POEO Act	Construction compliance reports Water quality records Environmental incident reports
MM SSWM4	All activities taking place in, on or under waterfront land, as defined in the <i>Water Management Act 2000</i> will be conducted in accordance with the <i>Dol Water's Guidelines for Controlled Activities</i> .	Construction	Environment and Sustainability Manager (or delegate)	Water Management Act 2000	Site inspection reports and other site work records
MM SSWM5	ESCPs will be prepared for all work sites associated with or in the vicinity of waterways and culverts that will be modified as part of the Project in accordance with the 'Blue Book' (Landcom 2004). ESCPs will be implemented in advance of site disturbance and will be updated as required as the work progresses and the sites change.	Pre-construction	Environment and Sustainability Manager (or delegate)	G38 REMM SW03 CoA E190	ESCPs Inspection reports
MM SSWM6	Training will be provided to relevant Project personnel, including relevant sub-contractors on sound erosion and sediment control practices and the requirements from this Plan through inductions, toolboxes, or targeted training.	Pre-construction and during construction	Environment and Sustainability Manager (or delegate)	G36/G38	Training, inductions, and toolbox records
MM SSWM7	Environmental Work Method Statements (EWMS) will be prepared prior to construction commences and implemented to manage soil and water impacts prior to commencing high risk activities.	Construction	Environment and Sustainability Manager (or delegate)	This Plan G36/G38	EWMS

ID	Measure/Requirement	When to implement	Responsibility	Reference	Evidence
Tunnel inflows					
MM SSWM8	Water Treatment Plant (WTP) for tunnel water discharge will be designed so that the water will be of suitable quality for discharge to the receiving environment in compliance with the discharge criteria (see Groundwater Monitoring Program (GWMP)), the Project EPL, the POEO Act and if applicable, JHCPB trade waste licence. Tunnels will be managed in a manner to reduce the impact of groundwater inflows and limit inflows as much as possible.	Pre-construction and during construction	Environment and Sustainability Manager (or delegate)	REMM SW10 GMP CoA E186	Water Monitoring reports
Erosion and sediment control					
MM SSWM9	<p>All erosion and sediment controls will be installed in accordance with best-practice guidelines such as the Blue Book. This may include (but not limited to):</p> <ul style="list-style-type: none"> ▪ Key management structures such as sediment traps and clean water diversions will be installed as interim measures to assist in effective site management before more permanent controls are installed; ▪ Turbid construction runoff will be directed into surface control structures (sumps, temporary controls including sediment fences and other sediment traps); ▪ Slope lengths will be maintained at appropriate lengths to slow flows down and minimise erosion; ▪ Temporary diversions will be implemented during construction to divert 'clean' offsite run-on so it doesn't come into contact with disturbed soils or sediment; ▪ Geotextile linings, soil binders, tarps or similar will be used to provide temporary surface protection where appropriate (e.g. batter drains, fills, cut faces); ▪ Use geotextile linings, black plastics, organic fibre matting, rock or similar to provide temporary surface protection in areas of concentrated flows (e.g. batter drains, piling platforms etc.) or in areas where sediment basins are required or are desirable to meet water quality objectives but cannot be provided due to space restrictions / current activities. Alternative erosion control measures should be selected consistent with Managing Urban Stormwater – Soils and Construction Volumes 1 	Construction	Environment and Sustainability Manager (or delegate)	REMM SW03 CoA E180 G38	Site inspection reports, ER inspection reports and ESCPs

ID	Measure/Requirement	When to implement	Responsibility	Reference	Evidence
	<p>and 2, 4th Edition (Landcom, 2004) and advise from the Project Soil Conservationist; and</p> <ul style="list-style-type: none"> Mulch bunds will not be used in concentrated flow areas, or if they have the potential to result in tannin leachate into waterways. 				
MM SSWM10	A soil conservation specialist will be engaged and retained for the Project duration to provide advice regarding erosion and sediment control and undertake risk-based inspections.	Construction	Environment and Sustainability Manager (or delegate)	REMM SW04 G38	Soil Conservationist reports and ESCP reviews
MM SSWM11	Works will be designed and programmed to minimise the extent and duration of disturbance to vegetation.	Pre-construction and during construction	Area Manager	G38	Site inspection report and other site work records
MM SSWM12	The extent of ground disturbance and exposed soil will be minimised to the greatest extent practicable to minimise the potential for erosion.	Construction	Environment and Sustainability Manager (or delegate)	REMM SW05	Site inspection reports, ER inspection reports and ESCPs
MM SSWM13	Disturbed ground and exposed soils will be temporarily stabilised during periods of site inactivity, for more than ten days, to minimise the potential for erosion.	Construction	Area Manager	REMM SW06	Site inspection reports, ER inspection reports and ESCPs
MM SSWM14	<p>Disturbed ground and exposed soils will be permanently stabilised and proposed landscaped areas suitably profiled and vegetated as soon as practicable following disturbance to minimise the potential erosion.</p> <ul style="list-style-type: none"> Re-spread topsoil over completed areas prior to revegetating. Ensure topsoil is properly keyed with subsoil, especially on slopes, to avoid slippage/slumping. Sediment controls will remain in place until their upslope catchment is stabilised as per the Blue Book (Landcom, 2004). Revegetated areas will be maintained as required. 	Post-construction	Area Manager	REMM SW07	Site inspection reports, ER inspection reports and ESCPs
MM SSWM15	Erosion and sediment control structures shall remain installed, inspected and maintained until sufficient stabilisation is achieved in the catchment	Construction	Environment and Sustainability Manager (or delegate)	G38	Site inspection reports, ER inspection reports and ESCPs

ID	Measure/Requirement	When to implement	Responsibility	Reference	Evidence
MM SSWM16	Measures will be implemented to minimise dust, soil or mud from being deposited by vehicles on public roads. This will be achieved by implementing mitigation measures such as rumble grids; large aggregate at entry/exit points; or wheel wash facilities.	Pre-construction and during construction	Area Manager	G38	Site inspection reports, ER inspection reports
MM SSWM17	Hardstand areas and surrounding public roads will be cleaned as required, using methods including brooms, bobcat attachments or street sweepers.	Pre-construction and during construction	Area Manager	G38	Site inspection reports, ER inspection reports
MM SSWM18	Where flocculation is necessary to settle suspended sediments in excavations, calcium sulfate (gypsum) will be utilised unless the use of alternative chemicals is approved in consultation with Roads and Maritime.	Construction	Area Manager	G38	Site inspection reports, ER inspection reports
Drainage and waterways					
MM SSWM19	<p>The road bridge crossing over and widening of Whites Creek, including all associated temporary and permanent infrastructure, will be designed and constructed in a manner consistent with:</p> <ul style="list-style-type: none"> ▪ Controlled Activities on Waterfront Land, Guidelines for watercourse crossings on waterfront land (NSW Department of Primary Industries (DPI) 2012) ▪ Why do Fish Need to Cross the Road? Fish Passage Requirements for Waterway Crossings (Fairfull and Witheridge 2003) ▪ Policy and Guidelines for Fish Friendly Waterway Crossings (NSW Fisheries February 2004) ▪ Policy and Guidelines for Fish Habitat Conservation and Management Update 2013 (DPI-Fisheries 2013) ▪ Design investigation will determine what the appropriate fish passage will be required if the concrete canal is a fish passage stream. <p>ESCPs are to dictate the specific controls to be used in and around works on watercourses or on live stormwater lines. Typical measures include:</p> <ul style="list-style-type: none"> ▪ Monitoring weather forecasts and taking appropriate action prior; ▪ Minimising the extent of work and the amount of time disturbance where possible; 	Design and Construction	Design Manager Area Manager	REMM SW08	Design Report Site inspection report

ID	Measure/Requirement	When to implement	Responsibility	Reference	Evidence
	<ul style="list-style-type: none"> ▪ Isolating work areas from natural flows where possible using steel plates, clean rock and other materials; ▪ Stockpiles to be located outside of the waterfront area and away from stormwater inlets; ▪ Use of temporary ground covers in areas of concentrated flow to minimise erosion of exposed soils during rainfall; and ▪ Completing and stabilising works as quickly as possible after works are complete. 				
MM SSWM20	<p>Where required, scour protection shall be installed within and at the base of permanent or temporary drainage features. Scour protection will be appropriately selected and may include (but is not limited to):</p> <ul style="list-style-type: none"> ▪ Rock lining. ▪ Concrete lining. ▪ Jute-mesh lining. ▪ Jute-matting. ▪ Geo-fabric lining ▪ Revegetation. ▪ Appropriate grade selection. ▪ Appropriately sized drains. <p>. Scour protection and energy dissipaters will be integrated where feasible into current banks to minimise impacts as soon as possible following the completion of any works within these areas</p>	Construction	Design Manager	G36/G38	Site inspection reports, ER inspection reports and ESCPs
Contamination and acid sulfate soils					
MM SSWM21	<p>Soil testing will be conducted at the following locations:</p> <ul style="list-style-type: none"> ▪ Rozelle civil and tunnel site; ▪ Any remnant areas (i.e. not validated as part of early works) across the Rozelle Rail Yards; ▪ The Crescent civil site; ▪ Any worksites within 40m of Rozelle Bay; ▪ The southern portion of Manning Street near Iron Cove. <p>If PASS is identified, it will be managed in accordance with the Acid Sulfate Soil Manual (ASSMAC 1998).</p>	Construction	Environment and Sustainability Manager (or delegate)	REMM SW11	Monitoring Data Waste Classification Reports Site inspection reports ER inspection reports

ID	Measure/Requirement	When to implement	Responsibility	Reference	Evidence
	<p>Management strategies will include:</p> <ul style="list-style-type: none"> ▪ Avoid land where PASS occurs; ▪ Avoid disturbing PASS if present on land; ▪ Undertake shallow soil disturbance so as not to disturb PASS at depth; ▪ Cover PASS with clean fill material; ▪ Set aside or do not disturb PASS material. 				
MM SSWM22	<p>Potentially contaminated areas directly affected by the Project will be investigated and managed in accordance with the requirements of guidance endorsed under section 105 of the Contaminated Land Management Act 1997 (NSW) (CLM Act).</p> <p>This may require further investigations in areas of potential contamination identified in the Project footprint. If contamination posing a risk to human or ecological receptors is identified, a Remediation Action Plan will be prepared.</p>	Construction	Environment and Sustainability Manager (or delegate)	REMM CM01	Contamination Reports (Phase 1 and 2) Unexpected Contaminated Land and Asbestos Finds Procedure
MM SSWM23	<p>Suitable areas will be identified to allow for contingency management of unexpected waste materials, including contaminated materials. Suitable areas will be hardstand or lined areas that are appropriately stabilised and bunded, with sufficient area for stockpile storage.</p>	Construction	Environment and Sustainability Manager (or delegate)	REMM RW9	ESCPs
MM SSWM24	<p>The discovery of previously unidentified contaminated material will be managed in accordance with the unexpected contaminated lands discovery procedure (Annexure B of the CLMP), as outlined in the Guideline for the Management of Contamination (Roads and Maritime 2013) and detailed in the CEMP.</p>	Construction	Environment and Sustainability Manager (or delegate)	REMM RW10	Unexpected Contaminated Land and Asbestos Finds Procedure
MM SSWM25	<p>An Asbestos Management Plan (or similar) will be prepared in accordance with relevant legislation, regulations and codes of practice.</p>	Pre-construction	Safety Manager	REMM CM02	Asbestos Management Plan
MM SSWM26	<p>An asbestos survey will be undertaken of buildings to be demolished in accordance with the Asbestos Management Plan. The survey will be conducted by a suitably qualified person.</p>	Pre-construction	Safety Manager	REMM RW13	Asbestos Management Plan
MM SSWM27	<p>Asbestos handling and management will be undertaken in accordance with the Asbestos Management Plan that has been prepared in accordance with relevant legislation, regulations and codes of practice. Adjacent communities will be provided with advance notification about potential hazards.</p>	Construction	Safety Manager	REMM RW14	Asbestos Management Plan Site inspection report

ID	Measure/Requirement	When to implement	Responsibility	Reference	Evidence
MM SSWM28	Unexpected contaminated land or asbestos finds will be managed in accordance with the Unexpected contaminated land and asbestos finds procedure (Annexure B of the CLMP). If remediation is required a Remediation Action Plan will be developed, approved and implemented. Then a validation report will be reviewed and approved by the Site Auditor before works can recommence.	Construction	Environment and Sustainability Manager (or delegate)	CoA E184, E185	Unexpected Contaminated Land and Asbestos Finds Procedure
Soil stockpiles					
MM SSWM29	Spoil stockpiles will be managed to reduce potential impacts associated with dust generation, erosion and sedimentation including by battering slopes or wetting to keep moist.	Construction	Environment and Sustainability Manager (or delegate)	REMM RW11 G38	ESCPs
MM SSWM30	Stockpiles of soil material will be sited within the Project boundary in low-hazard areas outside of waterfront corridors, away from the dripline of any retained trees, away from any drainage areas, and away from locations likely to receive run-off wherever possible.	Construction	Environment and Sustainability Manager (or delegate)	REMM RW11 G38	ESCPs
MM SSWM31	Weeds will be managed in accordance with the Project's Weed Management Protocol and the Flora and Fauna Management Plan.	Construction	Environment and Sustainability Manager (or delegate)	REMM RW11 G38	Site inspection report
MM SSWM32	Stockpiles left exposed and undisturbed for longer than 28 days will be contoured to minimise loss of material in flood or rainfall events and stabilised by: <ul style="list-style-type: none"> ▪ Spraying with suitable tackifier; ▪ Covering with anchored fabrics; and ▪ Seeding with sterile grass (topsoil only). 	Construction	Environment and Sustainability Manager (or delegate)	REMM RW11 G38	Site inspection report
MM SSWM33	Weed-free topsoils will be used for rehabilitation purposes wherever possible.	Construction	Environment and Sustainability Manager (or delegate)	REMM RW11 G38	Site inspection report
Chemicals, fuels, hazardous materials and concrete use					
MM SSWM34	Storage of dangerous goods and hazardous materials will occur in accordance with suppliers' instructions and relevant Australian Standards and legislation including the: <ul style="list-style-type: none"> ▪ <i>Work Health and Safety Act 2011 (NSW)</i> 	Construction	Area Manager	REMM HR1	Site inspection report

ID	Measure/Requirement	When to implement	Responsibility	Reference	Evidence
	<ul style="list-style-type: none"> Storage and Handling of Dangerous Goods Code of Practice (WorkCover NSW 2005) Environment Protection Manual for Authorised Officers: Bunding and Spill Management, technical bulletin (EPA 1997). <p>Incompatible chemicals will be stored separately in accordance with manufactures specifications and compatibility chart.</p>				
MM SSWM35	Secure, bunded areas will be provided around storage areas for oils, fuels and other hazardous liquids. Impervious bunds will be of sufficient capacity to contain at least 110 per cent of the volume of the largest stored container.	Construction	Area Manager	REMM HR2	Site inspection report
MM SSWM36	Hazardous substances will be stored onsite in lockable containers or on a bund within a secure area, in their original receptacles.	Construction	Area Manager	REMM HR2	Site inspection report
MM SSWM37	All hazardous substances will be clearly labelled and will have Safety Data Sheets affixed or available nearby.	Construction	Safety Manager	REMM HR2	Site inspection report
MM SSWM38	An up-to-date register of hazardous substances will be kept onsite at all times.	Construction	Safety Manager	REMM HR2	Site inspection report
MM SSWM39	Any concrete washout areas will be adequately sized and regularly maintained. Where possible, washouts will be located in covered areas. They will be outside of riparian areas and well away from stormwater system inlets in a position where wastewater will not enter any drainage lines or waterways.	Construction	Environment and Sustainability Manager (or delegate)	REMM HR3	Site inspection report
MM SSWM40	Hazardous substances will only be used onsite as required, in accordance with the manufacturer/supplier instructions. The use hazardous substances inside tunnels will be minimised as much as possible.	Construction	Environment and Sustainability Manager (or delegate)	REMM HR2	Site inspection report
Spills prevention and incidents					
MM SSWM42	<p>The use of any hazardous substances, including any dangerous goods as defined by the Australian Dangerous Goods Code, must be stored and handled in accordance with:</p> <ul style="list-style-type: none"> Work Health and Safety Act 2011 (NSW) All relevant Australian Standards AS 1940-1993 – The Storage and Handling of Flammable and Combustible Liquids; 	Construction	Area Manager	REMM HR3	Site inspection report

ID	Measure/Requirement	When to implement	Responsibility	Reference	Evidence
	<ul style="list-style-type: none"> For liquids, a bund size 110% of the largest stored receptacle will be established around any storage area for hazardous substances. OEH and EPA guidelines for bunding and spill management including the Environment Protection Manual for Authorised Officers: Bunding and Spill Management, Storing and Handling Liquids: Environmental Protection, Participants Manual (DECC 2007) <p>These substances will be handled and stored away from drainage or stormwater lines within defined bunds wherever practicable.</p>				
MM SSWM43	Any refuelling undertaken on site shall be undertaken in designated areas only, outside of waterfront areas and well away from stormwater system inlets.	Construction	Area Manager	REMM HR3 G36	Site inspection report
MM SSWM44	Spills or leakages will be immediately contained and absorbed using a spill kit and in accordance with the Spill Management Procedure. Minor spills will be cleaned up and reported using the Roads and Maritime Incident Reporting Procedure.	Construction	Area Manager	REMM HR3	Incident report Spill Management Procedure
MM SSWM46	Spill containment kits will be placed at locations with a high concentration of plant or machinery, at hazardous substance storage locations and at refuelling points. Vehicles will be properly maintained to minimise the risk of fuel/oil leaks and routine inspections of construction equipment will be undertaken to identify any fuel/oil leaks and repairs made as required.	Construction	Environment and Sustainability Manager (or delegate) Plant Manager	REMM HR3	Incident report
Flooding					
MM SSWM47	Runoff generated from Project construction facilities and discharges from water treatment facilities will be managed through the Flood Mitigation Strategy to mitigate risk of overloading the receiving drainage system. The rainfall forecast will be monitored to identify and communicate the risk of potentially flooding rains.	Construction	Area Manager	REMM FD13	Site inspection report
MM SSWM48	Entry points to the stormwater system used by, or immediately downgradient from, the Project sites will be inspected regularly for blockages and cleaned as required to maintain performance.	Construction	Environment and Sustainability Manager (or delegate)	REMM FD14	Site inspection report
Monitoring					

ID	Measure/Requirement	When to implement	Responsibility	Reference	Evidence
MM SSWM49	A surface water quality monitoring program will be implemented to monitor potential surface water quality impacts due to the Project. This Program was developed in accordance with the Project EPL #21278.	Construction	Environment and Sustainability Manager (or delegate)	CoA C10 REMM SW02 Annexure B	Water monitoring report
Records					
MM SSWM50	Records of surface water monitoring and dewatering activities will be kept for a minimum period of four years and will be available for review by the relevant parties upon request and consistent with the powers of the authority.	Construction	Environment and Sustainability Manager (or delegate)	G38 Annexure B GWMP	Discharge Permit
Site inspections, maintenance and rainfall events					
MMSSWM51	All environmental control measures across the site will be inspected at least weekly, prior to forecast rainfall of 10mm and within 24 hours of rainfall causing runoff (if safe to do so), and prior to any site shut-down/closure greater than 48 hours. Records of these inspections will be kept, and appropriate action taken to repair any damage, maintain (clean out) controls and/or install additional controls as required.	Construction	Environment and Sustainability Manager (or delegate)	G36 Annexure B	Site inspection report
MM SSWM52	Concrete wash out points; <ul style="list-style-type: none"> ▪ are not to be used once full ▪ usage is to be supervised by foreman/leading hands ▪ will be regularly inspected by environment team ▪ must be regularly cleaned out (and handled in accordance with the POEO Waste Regulation). 			G36	Site inspection report
MM SSWM53	Prior to forecast rainfall events of 10mm, end-of-day controls will be implemented throughout the worksite to help reduce erosion and sediment control. These will be listed on the ESCP and may include one or more of the following: <ul style="list-style-type: none"> ▪ Check dams; ▪ Slope breaks; ▪ Batter chutes; ▪ Fill windrows; and ▪ Temporary ground covers. 	Construction	Environment and Sustainability Manager (or delegate)	G36	Site inspection report

ID	Measure/Requirement	When to implement	Responsibility	Reference	Evidence
MM SSWM54	<p>Prior to forecast heavy rainfall (>20mm), the site will be inspected to identify any areas requiring additional management measures, such as:</p> <ul style="list-style-type: none"> ▪ Dewatering (discharge or reuse) sediment basins and/or water holding tanks to lower water level; ▪ Place additional line of sediment fencing, gravel bags/coir logs, sand bags, sediment traps as required; and ▪ Construct additional clean stormwater catch drains, slope break, diversions as required. 	Construction	Environment and Sustainability Manager (or delegate)	G36	Site inspection report
Waterfront land					
MM SSWM55	<p>ESCPs are to dictate the specific controls to be used in and around works on watercourses or on live stormwater lines. Typical measures might include but are not limited to:</p> <ul style="list-style-type: none"> ▪ Timing in-stream works for lower-risk periods wherever practicable; ▪ Monitoring weather forecasts and taking appropriate action prior to forecast rainfall; ▪ Minimising the extent of work and the amount of time of disturbance where possible; ▪ Isolating work areas from natural flows where possible using diversion structures, pumps, temporary dams or similar; ▪ Use of temporary ground covers in areas of concentrated flow to minimise erosion of exposed soils during rainfall; and ▪ Stabilising flow paths as quickly as possible after works are completed. 	Construction	Environment and Sustainability Manager (or delegate)	G38	ESCP EWMS
MM SSWM56	Any temporary crossing points at waterways (if used) will be stabilised to minimise the risk of scour and will be constructed of clean rock or similar.	Construction	Environment and Sustainability Manager (or delegate)	G38	ESCP EWMS
MM SSWM57	Clean materials will be used in waterways as required to form dissipaters, piling platforms, create crossing points or line channels.	Construction	Environment and Sustainability Manager (or delegate)	G38	ESCP

ID	Measure/Requirement	When to implement	Responsibility	Reference	Evidence
MM SSWM58	Stabilisation of waterways including their beds and banks is to be commenced as soon as possible following the completion of any works within these areas.	Construction	Environment and Sustainability Manager (or delegate)	G38	ESCP EWMS
MM SSWM59	Watercourses and waterfront land will be left undisturbed as much as possible. Where watercourses and waterfront land are to be disturbed, EWMS will be prepared before construction commences.	Design Pre-Construction	Environment and Sustainability Manager (or delegate)	G38	EWMS
MM SSWM60	Prior to forecast rainfall events of more than 10mm in 24 hours (>50% chance), end of day controls will be implemented throughout the worksite to help reduce erosion and control sediment. These are to be detailed on ESCPs for each area.	Construction	Environment and Sustainability Manager (or delegate)	G38	Site inspection report
MM SSWM61	Long-term (>10 days) stockpiling of spoil material will not occur within 40m of a named watercourse.	Construction	Environment and Sustainability Manager (or delegate)	G38	Site inspection report
Discharge events from Licenced sediment basins and construction water treatment plants					
MM SSWM62	A Permit to Dewater will be raised for every discharge event. This permit will monitor the compliance with the discharge criteria listed in the Project EPL (#21278). The Permit to Dewater can only be raised and approved by a competently trained member of the JHGCPB environmental team.	Construction	Environment and Sustainability Manager (or delegate)	EPL	Permit to Dewater Register of Licence Discharge Points Register of team members trained in approving Permit to Dewater.

7. Compliance management

7.1. Roles and responsibilities

The JHCPB Project Team's organisational structure and overall roles and responsibilities are outlined in Section 3.3 of the CEMP. Specific responsibilities for the implementation of environmental controls are detailed in Section 6 of this Plan.

7.2. Training

7.2.1. Inductions

All employees, contractors and utility staff working on site will undergo site induction training relating to soil and surface water management issues. The induction training will address elements related to soil and surface water management including:

- Existence and requirements of this Plan,
- Existence and requirements of the PIRMP,
- Relevant legislation,
- Roles and responsibilities for soil and surface water management,
- The location and identification of acid sulfate soil or contamination,
- Water quality management and protection measures, and
- Procedure to be implemented in the event of an unexpected discovery of contaminated land.

Elements identified above may be delivered in targeted training relevant to personnel who may interact with the above issues rather than the induction.

7.2.2. Toolbox training

Targeted training in the form of toolbox talks or specific training will also be provided to personnel with a key role in soil and surface water management. Examples of training topics include:

- Erosion and sediment control installation methodology and maintenance,
- WTP management including monitoring of discharge,
- Compliant monitor methodology,
- Dewatering monitoring and management,
- Emergency response measures in high rainfall events,
- Preparedness for high rainfall events, and
- Lessons learnt from incidents and other event (e.g. high rainfall/flooding).

Further details regarding staff induction and training are outlined in Section 3.5 of the CEMP.

7.3. Monitoring and inspection

7.3.1. Monitoring

The SWQMP (Annexure B) provides detailed inspection criteria including:

- Surface water quality monitoring locations,
- Parameters/analytes to be monitored,
- Type and frequency of monitoring, and
- Monitoring methodology.

7.3.2. Inspections

Regular monitoring and inspections will be undertaken and will include, but not be limited to:

- Weekly inspections by Environment team personnel at active, exposed work sites to evaluate the effectiveness of erosion and sediment controls measures in accordance with Section 3.8.1 and 3.8.2 of the CEMP,

- Rainfall inspections will be conducted prior to a forecast of >25 mm over a 24 hour period at active exposed work sites to assess site preparedness for upcoming predicted rainfall event,
- Rainfall inspections will be conducted after rainfall events that generate runoff from site, to evaluate the effectiveness of erosion and sediment controls measures in accordance with Section 3.9.1 and 3.9.2 of the CEMP,
- Inspections will be undertaken of erosion and sediment controls prior to any shut down greater than 48 hours,
- Construction discharge water (including tunnel inflows) will be tested, treated, reused or discharged, recorded and reported to meet the requirements of the Project EPL, CoA (Annexure A), and if applicable, JHCPB trade waste licence, and
- Surface water monitoring will be conducted, recorded and reported in accordance with the Project EPL. The location and frequency of monitoring will be in accordance with the SWQMP (Annexure B).

Where a non-conformance is detected or monitoring results are outside of the expected range and are directly attributable to the Project, the process described in Section 3.9.2 of the CEMP will be implemented. Steps in the process will include:

- An analysis of the results by the JHCPB Environment and Sustainability Manager with a view of determining possible causes for the non-conformance,
- A site inspection by the JHCPB Environment and Sustainability Manager or delegate,
- Advising relevant personnel of the problem,
- Identifying and agreeing on actions to resolve or mitigate the non-conformance, and
- Implementing actions to rectify or mitigate the non-conformance.

Opportunities for improvement of the monitoring and inspection processes will be identified through Section 8 of this Plan.

Additional requirements and responsibilities in relation to inspections are documented in Section 3.9.1 and 3.9.2 of the CEMP.

7.3.3. Role of Soil Conservationist

In some cases, a suitably qualified Soil Conservationist will be engaged to provide input and advice. This will occur in the following instances:

- To provide advice on the development and review of relevant plans (including ESCPs and management plans) and their consistency with the Blue Book,
- To assist with reviewing significant changes to sites that cause a fundamental alteration to input parameters, or after a significant change to site layouts (e.g. after a traffic switch which opens up a new area and impacts the drainage),
- Assist with identification of works that classify as high erosion hazard (including in waterfront land, and elsewhere) and prepare or review ESCPs for those works,
- Assist with assessing whether sediment basins are required in accordance with the Blue Book,
- Inspect the site and provide advice in circumstances if existing controls are failing or pollution has occurred.

7.4. Licences and permits

The Project construction activities will be regulated by an EPL issued by the EPA and the SWQMP (refer to Annexure B).

The EPL typically prescribes water quality parameters to be measured and associated discharge criteria for the licensed discharge points. The EPL also details the monitoring and analytical requirements by reference to authority publications (e.g. Approved Methods for Sampling and Analysis of Water Pollutants in NSW (EPA 2004)).

An access licence has been agreed between Sydney Water and the Proponent to allow for road construction, construction of a shared path bridge and duplication / widening at Whites Creek, including all work ancillary to such works such as drainage works, landscaping works, utility relocation and traffic control.

Other relevant licences or permits will be obtained in the lead up to and during construction as required.

7.5. Weather monitoring

Weather (rainfall, temperature, wind speed/direction) will be monitored during the construction phase via a nearby Bureau of Meteorology weather station (e.g. Sydney Observatory Hill). Key Project personnel, such as Superintendents will be trained to utilise Project issued smart phones to monitor weather. If a significant rain event is anticipated, all “shut-down” controls detailed in the ESCPs will be implemented prior to the rainfall event. This may include stabilisation of exposed areas and stockpiles, water diversions. Should a flood event be predicted all chemicals Etc will be removed from the potential flood area.

Rainfall at the Rozelle Railyards premise will be measured and recorded in millimetres per 24-hour period at the same time each workday from the time that the site office associated with the activities is established.

7.6. Auditing

Audits (both internal and external) will be undertaken to assess the effectiveness of environmental controls, compliance with this sub plan, CoA and other relevant approvals, licenses and guidelines.

Audit requirements are detailed in Section 3.9.3 of the CEMP.

7.7. Reporting

Reporting is required as part of this Plan to ensure Project management is responsive and appropriate. Table 12 details the reporting schedule.

Table 12 Details the proposed reporting schedule

Project phase	Report timing	Report requirements
During construction	Weekly	Weekly inspection report undertaken by environmental advisor
	Fortnightly	Environmental Representative Fortnightly Inspection Report
	Six-monthly	All reporting as required by the SWQMP.
		Report on SWQMP quality results obtained during construction. Determine the need for adjustments to the SWQMP, if necessary.
		Document rainfall data.
	12-monthly	Reporting in accordance with the relevant EPL.
Summary report of water monitoring data required under the Water Quality Monitoring Program, including any relevant findings, to be provided to the Department of Planning and Environment (DPE) and EPA.		
Audits of performance against SSWMP requirements as detailed in Section 6.		
After construction	Six-monthly for a period of three years	All reporting as required by the SWQMP.
		Determine the need for continuation of the SWQMP

8. Review and improvement

8.1. Continuous improvement

Continuous improvement of this Plan will be achieved by the ongoing evaluation of environmental management performance against environmental policies, objectives and targets for the purpose of identifying opportunities for improvement.

The continuous improvement process will be designed to:

- Identify areas of opportunity for improvement of environmental management and performance,
- Determine the cause or causes of non-conformances and deficiencies,
- Develop and implement a plan of corrective and preventative action to address any non-conformances and deficiencies,
- Verify the effectiveness of the corrective and preventative actions,
- Document any changes in procedures resulting from process improvement, and
- Make comparisons with objectives and targets.

Should the review process of this Plan identify any issues or items within that are either redundant or in need of updating, it is the responsibility of the JHCPB Environment and Sustainability Manager (or delegate) to prepare the revised documents. The revised document will then be issued to the Project Director for internal approval, and to the Environmental Representative (ER) for endorsement of the changes. Where required, the Soil Conservationist will be engaged to provide assistance during the life cycle of the Project. The ER can approve minor changes to the CEMP and sub-plans in accordance with section 3.13 of the CEMP.

8.2. SSWMP update and amendment

The processes described in Section 3.13.1 and Section 3.13.2 of the CEMP may result in the need to update or revise this Plan. This will occur as needed.

Only the Environment and Sustainability Manager, or delegate, has the authority to change any of the environmental management documentation.

A copy of the updated plan and changes will be distributed to all relevant stakeholders in accordance with the approved document control procedure – refer to Section 3.11.2 of the CEMP.

9. References

- AECOM, 2017. WestConnex M4-M5 EIS Technical Working Paper: Surface Water and Flooding, August 2017.
- Australian and New Zealand Environment and Conservation Council and Agriculture and Resource Management Council of Australia and New Zealand (ANZECC), 2000. National Water Quality Management Strategy, Paper No. 4, Australian and New Zealand Guidelines for Fresh and Marine Water Quality, Volume 1.
- Acid Sulfate Soils Management Advisory Committee (ASSMAC), 1998. Acid Sulfate Soil Manual.
- Bureau of Meteorology (BoM), 2018. Climate data from Sydney Airport (station ID: 66037), accessed July 2018.
- Department of Environment and Conservation (DEC), 1998. Bunding & Spill Management. Insert to the Environment Protection Manual for Authorised Officers - Technical section "Bu".
- DEC, 2004. Environmental Best Management Practice Guideline for Concreting Contractors.
- DEC, 2006. Guidelines for the Site Auditor Scheme (Second Edition) (NSW Department of Environment and Conservation).
- DEC, 2007. Guidelines for the Assessment and Management of Groundwater Contamination.
- Department of Environment Climate Change and Water (DECCW), 2008. Volume 2D Main Roads Construction.
- Department of Conservation and Land Management (DCLM), 1989. Soil Landscapes of the Sydney 1:100,000, Sheet 9130
- Environment Protection Authority (EPA), 2004. Approved Methods for the Sampling and Analysis of Water Pollutants in NSW.
- EPA, 2015. Guidelines on the Duty to Report Contamination under the Contaminated Land Management Act 1997.
- Fairfull, S. and Witheridge, G., 2003. Why do Fish Need to Cross the Road? Fish Passage Requirements for Waterway Crossings. NSW Fisheries.
- Infrastructure Sustainability Council of Australia (ISCA), 2016. IS technical manual (Version 1.2). Sydney, NSW Infrastructure Sustainability Council Pty Ltd
- Landcom, 2004. Managing Urban Stormwater: Soils and Construction. Landcom, (4th Edition) March 2004 (reprinted 2006) (the "Blue Book"). Volume 1 and Volume 2.
- National Environment Protection Council (NEPC), 1999. National Environment Protection (Assessment of Site Contamination) Measure (ASC NEPM) 2013.
- NSW Fisheries, 2003. Fishnote – Policy and Guidelines for Fish Friendly Waterway Crossings (Ref: NSWF – 1181).
- Roads and Maritime Services (Roads and Maritime), 2011. Road and Maritime Dewatering Guideline.
- Roads and Maritime, 2014. Roads and Maritime Management of Wastes on Roads and Maritime Services Land.
- Roads and Maritime, 2011. Roads and Maritime Stockpile Site Management Guideline.
- Roads and Maritime, 2012. Roads and Maritime Environment Direction Management of Tannins from Vegetation Mulch.
- Roads and Traffic Authority (RTA), 1999. RTA's Code of Practice for Water Management – Road Development and Management.

Annexure A Other Conditions of Approval and Revised Environmental Mitigation Measures relevant to this Plan

Other relevant Conditions of Approval relevant to the development of this Plan.

CoA No.	Condition Requirements	Document Reference
E180	All reasonably practicable erosion and sediment controls must be installed and appropriately maintained to minimise any water pollution. When implementing such controls, any relevant guidance in the Managing Urban Stormwater series must be considered.	Table 11 SSWM4, SSWM5 SSWM7, SSWM9 to SSWM18
E186	The CSSI construction water treatment plant discharge criteria must comply with the ANZECC (2000) 90 per cent species protection level unless an EPL is in force in respect to the CSSI. Discharge criteria for iron during construction must comply with the ANZECC (2000) recreational water quality criteria.	Table 11 SSWM8
E188	Drainage feature crossings (permanent and temporary watercourse crossings and stream diversions) and drainage swales and depressions must be undertaken in accordance with relevant guidelines and designed by a suitably qualified and experienced person.	Table 11 SSWM19 SSWM20
E189	Works on waterfront land must be undertaken in accordance with DPI controlled activity guidelines.	Table 9 - SSWM 4

Revised Environmental Mitigation Measures relevant to the development of this Plan.

Impact	Ref#	Commitment	Timing	SSWMP Reference
Impacts on surface water quality	REMM SW01	A Construction Soil and Water Management Plan (SSWMP) will be prepared for the Project. The plan will include the measures that will be implemented to manage and monitor potential surface water quality impacts during construction. This Plan will be developed in accordance with the principles and requirements in Managing Urban Stormwater – Soils and Construction, Volume 1 (Landcom 2004) and Volume 2D (NSW Department of Environment, Climate Change and Water 2008), commonly referred to as the 'Blue Book'.	Pre-construction	This Plan
	REMM SW02	A program to monitor potential surface water quality impacts due to the Project will be developed and included in this Plan. The program will include the water quality monitoring parameters and the monitoring locations identified in Annexure E of Appendix Q (Technical working paper: Surface water and flooding) to the EIS where appropriate. The monitoring program will commence prior to any ground disturbance to establish appropriate baseline conditions and continue for the duration of construction and until the affected waterways are rehabilitated to an acceptable condition as certified by a suitably qualified and experienced independent expert (or as otherwise required by any Project conditions of approval). Further details to be included in the program are outlined in Appendix Q (Technical working paper: Surface water and flooding) of the EIS.	Construction	Table 11 SSWM48 SWQMP
Sedimentation of waterways	REMM SW03	ESCPs will be prepared in accordance with the Blue Book Volumes 1 and 2D (Landcom, 2004 and DECC, 2008) for each specific stage or parcel of	Prior to construction	Table 11 SSWM5

Impact	Ref#	Commitment	Timing	SSWMP Reference
		work prior to commencing construction in consultation with construction staff. These will be updated as required.		
	REMM SW04	A soil conservation specialist will be engaged for the duration of construction to provide advice regarding erosion and sediment control.	Construction	Table 11 SSWM10
	REMM SW05	The extent of ground disturbance and exposed soil will be minimised to the greatest extent practicable to minimise the potential for erosion.	Construction	Table 11 SSWM12
	REMM SW06	Disturbed ground and exposed soils will be temporarily stabilised prior to extended periods of site inactivity to minimise the potential for erosion.	Construction	Table 11 SSWM13
	REMM SW07	Disturbed ground and exposed soils will be permanently stabilised and proposed landscaped areas will be suitably profiled and vegetated as soon as possible following disturbance to minimise the potential erosion.	Construction	Table 11 SSWM14
Impacts on the form and aquatic habitat of Whites Creek	REMM SW08	The proposed bridge crossing over and widening of Whites Creek, including all associated temporary and permanent infrastructure, will be designed and constructed in a manner consistent with: <ul style="list-style-type: none"> Controlled Activities on Waterfront Land, Guidelines for watercourse crossings on waterfront land (NSW Department of Primary Industries (DPI) 2012) Why do Fish Need to Cross the Road? Fish Passage Requirements for Waterway Crossings (Fairfull and Witheridge 2003) Policy and Guidelines for Fish Friendly Waterway Crossings (NSW Fisheries February 2004) Policy and Guidelines for Fish Habitat Conservation and Management Update 2013 (DPI-Fisheries 2013) Appropriate fish passage will be provided for crossings of fish habitat streams. 	Pre-construction	Table 11 SSWM19
	REMM SW09	Consultation will be undertaken with Sydney Water regarding the timing of the works at Whites Creek and compatibility of the proposed design and Sydney Water's naturalisation works.	Pre-construction	Section 3.4
Impacts on water quality from the discharge of treated	REMM SW10	Temporary construction water treatment plants will be designed and managed so that treated water will be of suitable quality for discharge to the receiving environment.	Pre-construction	Table 11 SSWM8

Impact	Ref#	Commitment	Timing	SSWMP Reference
wastewater during construction		An ANZECC (2000) species protection level of 90 per cent is considered appropriate for adoption as discharge criteria for toxicants where practical and feasible. The discharge criteria for the treatment facilities will be included in the CSSWMP.	and during construction	
Impacts on water quality from disturbance of acid sulfate soils	REMM SW11	Procedures, prepared in accordance with the requirements of the Acid Sulfate Soil Manual (ASSMAC1998), will be included in the CSSWMP and implemented in the event that acid sulfate soils, rocks or monosulfidic black oozes are encountered during construction of the Project	Construction	Acid Sulfate Soils Management Procedure Table 11 SSWM21
Impacts on human and/or ecological receptors through disturbance and mobilisation of contaminated material	REMM CM01	Potentially contaminated areas directly affected by the Project will be investigated and managed in accordance with the requirements of guidance endorsed under section 105 of the <i>Contaminated Land Management Act 1997</i> (NSW) (CLM Act). This includes further investigations in areas of potential contamination identified in the Project footprint. If contamination posing a risk to human or ecological receptors is identified, a Remediation Action Plan will be prepared.	Construction	Table 11 SSWM22
Impacts on stormwater drainage systems	REMM FD13	Runoff generated from Project construction and operational facilities and discharges from water treatment facilities will be managed to mitigate risk of overloading the receiving drainage system.	Construction	Table 11 SSWM47
	REMM FD14	Entry points to the stormwater used by or immediately downgradient from the Project sites will be inspected regularly for blockages and cleaned as required to maintain performance.	Construction	Table 11 SSWM48

Annexure B Surface Water Quality Monitoring Program

JHCPB Joint Venture

Surface Water Quality Monitoring Program

RIC-JHC-MPL-00-PL-270-002

Project	Design and Construction of Rozelle Interchange Project
Design Lot No.	00-PL-270
Document No.	RIC-JHC-MPL-00-PL-270-002
Revision Date	16 December 2020

Document Approval

Developed By:				
Name: [REDACTED]		[REDACTED]		
Reviewed By:				
Name		Position		Date Reviewed
[REDACTED]		[REDACTED]		[REDACTED]
Revision Record				
Rev	Rev Date	Reason for issue	Developed by	Approved by
A	26/03/2019	Draft for RMS review	[REDACTED]	
B	05/04/2019	Issued for consultation	[REDACTED]	
C	02/05/2019	Updated in response to RMS, ER comments	[REDACTED]	
00	14/05/2019	For submission to DPE	[REDACTED]	
01	27/06/2019	Updated in response to DPE comments	[REDACTED]	
02	11/07/2019	Updated in response to DPE comments	[REDACTED]	
03	23/09/2020	Updated in response to Modification approvals for approval by ER	[REDACTED]	[REDACTED]
04	16/12/2020	For DPIE approval	[REDACTED]	

Contents

1. Introduction.....	6
1.1. Context.....	6
1.2. Scope of the SWQMP	6
2. Purpose and objectives.....	7
2.1. Purpose.....	7
2.2. Objectives	7
2.3. Consultation	7
3. Surface water monitoring	8
3.1. Baseline monitoring.....	8
3.1.1. Overview.....	8
3.1.2. Monitoring network	8
3.1.3. Surface water quality	11
3.2. Surface water quality construction monitoring	12
3.2.1. Overview.....	12
3.2.2. Rainfall monitoring	12
3.2.3. Monitoring locations.....	12
3.2.4. Sampling frequency	13
3.2.5. Surface water quality parameters.....	13
3.2.6. Performance criteria.....	14
4. Monitoring methodology / Sampling protocol.....	15
4.1. Sampling collection	15
4.2. Field measures.....	15
4.3. Recording of field results	15
4.4. Decontamination	15
4.5. Quality Assurance and documentation	15
5. Compliance management	16
5.1. Roles, responsibility, and training	16
5.2. Monitoring and inspection.....	16
5.3. Data analysis and management response.....	16
5.4. Auditing	16
5.5. Reporting.....	16
6. Review and improvement.....	17
6.1. Continuous improvement.....	17
6.2. SWQMP update and amendment.....	17
7. References	18

Table of Figures

Figure 1 Rozelle Interchange showing sampling locations (SW03 and SW04 will not be monitored for this project and are associated with the Mainline Tunnels Project)..... 9

Figure 2 Iron Cove Link showing sampling locations..... 10

Table of Tables

Table 1 Baseline surface water monitoring locations..... 8

Table 2 Baseline surface water quality sampling program..... 11

Table 3 Baseline water quality conditions in the Project area..... 11

Table 4 Construction phase surface water monitoring program..... 12

Table 5 Surface water quality monitoring parameters 13

Table 6 Site specific trigger values..... 14

Table 7 Reporting requirements..... 17

Annexures

Annexure A Baseline surface water monitoring results..... 19

Glossary/ Abbreviations

Abbreviations	Expanded text
CEMP	Construction Environmental Management Plan
CoA	Conditions of Approval
DoI Water	Department of Industry – Water (formerly DPI Water)
EC	Electrical Conductivity
EIS	WestConnex M4-M5 Link Environmental Impact Statement
EPL	Environment Protection Licence
GMP	Groundwater Management Sub-plan
JHCPB	John Holland CPB Contractors Joint Venture
REMM	Revised Environmental Management Measures
Roads and Maritime	Roads and Maritime Services
SPIR	WestConnex M4-M5 Link Submissions and Preferred Infrastructure Report
SSTV	Site Specific Trigger Values
SSWMP	Soil and Water Management Plan
SWQMP	Surface Water Quality Monitoring Program
TDS	Total Dissolved Solids
WTP	Water Treatment Plant

1. Introduction

1.1. Context

This Surface Water Quality Monitoring Program (the Program) has been prepared for the Design and Construction of Rozelle Interchange Project (the Project). The Program forms Appendix B of the Soil and Surface Water Management Sub-plan (SSWMP).

This Program has been prepared to address the requirements of the Ministers Conditions of Approval (CoA), Project Approvals and all applicable guidance and legislation.

1.2. Scope of the SWQMP

The scope of this Program is to describe how John Holland CPB Contractors Joint Venture (JHCPB) proposes to monitor potential impacts to surface water during construction of the Project. Operational monitoring and operation measures do not fall within the scope of the construction phase and therefore are not included within the processes contained within this Program.

2. Purpose and objectives

2.1. Purpose

The purpose of the Program is to describe how JHCPB will monitor surface water quality during construction of the Project.

The Program will be implemented to monitor the effectiveness of mitigation measures applied during the construction phase of the Project. Monitoring of surface water will be undertaken to identify potential impacts and ensure an appropriate management regime can be implemented to address those impacts and manage local surface water quality.

This Program provides details of the surface water monitoring network, frequency of monitoring, and test parameters. This Program supplements the SWMP, which itself is an appendix of the Construction Environmental Management Plan (CEMP).

This Program is based on baseline studies developed for the project EIS (AECOM, 2017).

2.2. Objectives

The key objectives of this Program are to ensure all CoAs, REMMs, and licence/permit requirements relating to surface water monitoring are described, scheduled, and assigned responsibility as outlined in:

- The EIS prepared for WestConnex M4-M5 Link,
- The SPIR prepared for WestConnex M4-M5 Link,
- The Modification Report and Response to Submissions Report prepared for the Mainline Tunnel Modification,
- Conditions of Approval granted to the project on 17 April 2018 and as subsequently modified,
- RMS specifications G36, G38 and G40,
- The Project's Environment Protection Licence (EPL) issued on 18 June 2019 with a Section 58 Licence Variation issued on 18 August 2020, and
- All relevant legislation and other requirements described in Section 3 of the SSWMP.

2.3. Consultation

This program was provided to DoI Water, Sydney Water and Inner West Council in accordance with CoA C9(a). Refer to Section 3.7.2 of the CEMP for the consultation requirements relating to the CEMP and all sub-plans.

Ongoing consultation with relevant councils and other stakeholders, including any unique local receivers, will be undertaken for particular issues pertaining to the Project's impact on soil and surface water as required by CoA C4(e) and C9(a). Community feedback and complaints relating to surface water quality will be managed in accordance with the Communication Strategy and Complaints Management System.

3. Surface water monitoring

3.1. Baseline monitoring

3.1.1. Overview

In July 2016 a baseline surface water monitoring program was implemented as part of the project EIS (AECOM, 2017). The program was based on a desktop assessment involving a review of the existing surface water environment across the project area, including:

- Information obtained from geotechnical investigations and assessments carried out as part of the project,
- Information and water quality monitoring data from the M4 East EIS and the New M5 EIS relevant to surface water within the project area, and
- Data relevant to the existing surface water conditions in the study area from sources including the Inner West Council and the City of Sydney Council, WestConnex (formerly Sydney Motorway Corporation, and NSW Government agencies including Sydney Water and the RMS.

The baseline surface water monitoring program was implemented to:

- Evaluate the existing surface water quality at key locations in the project area,
- Identify potential pathways of pollutants to surface water receivers, and
- Monitor and assess the surface water quality in the project area to form a baseline of environmental conditions, to measure the environmental performance of the project during the construction and operation of the project.

3.1.2. Monitoring network

Baseline water quality monitoring locations were located upstream and downstream of the Project alignment and ancillary facilities as shown in Figure 1, Figure 2 and listed in Table 1. Monitoring locations SW03 and SW04 shown on Figure 1 are associated with the M4-M5 Link Mainline Tunnels Project and are not included in the monitoring program established by this Program. The monitoring locations were chosen to provide general characterisation of the waterways in the vicinity of the Project and include water quality monitoring locations established for the Project.

Table 1 Baseline surface water monitoring locations

Sample ID	Sample Location	Waterway
SW01	Whites Creek outlet at City West Link/ The Crescent, Rozelle	Rozelle Bay (downstream of construction)
SW02	Whites Creek Valley Park, Railway Parade, Annandale	Whites Creek (downstream of construction)*
SW07	Adjacent to 88-90 Lilyfield Road, Lilyfield	Easton Park drain (upstream of construction)
SW11	Under Iron Cove Bridge, Rozelle	Iron Cove (downstream of construction)
SW12	King George Park, Rozelle	Iron Cove (downstream of construction)

* SW02 is listed as downstream of the M4-M5 link construction compounds in the EIS (AECOM, 2017). However, SW02 is upstream of the Rozelle Interchange construction compound.

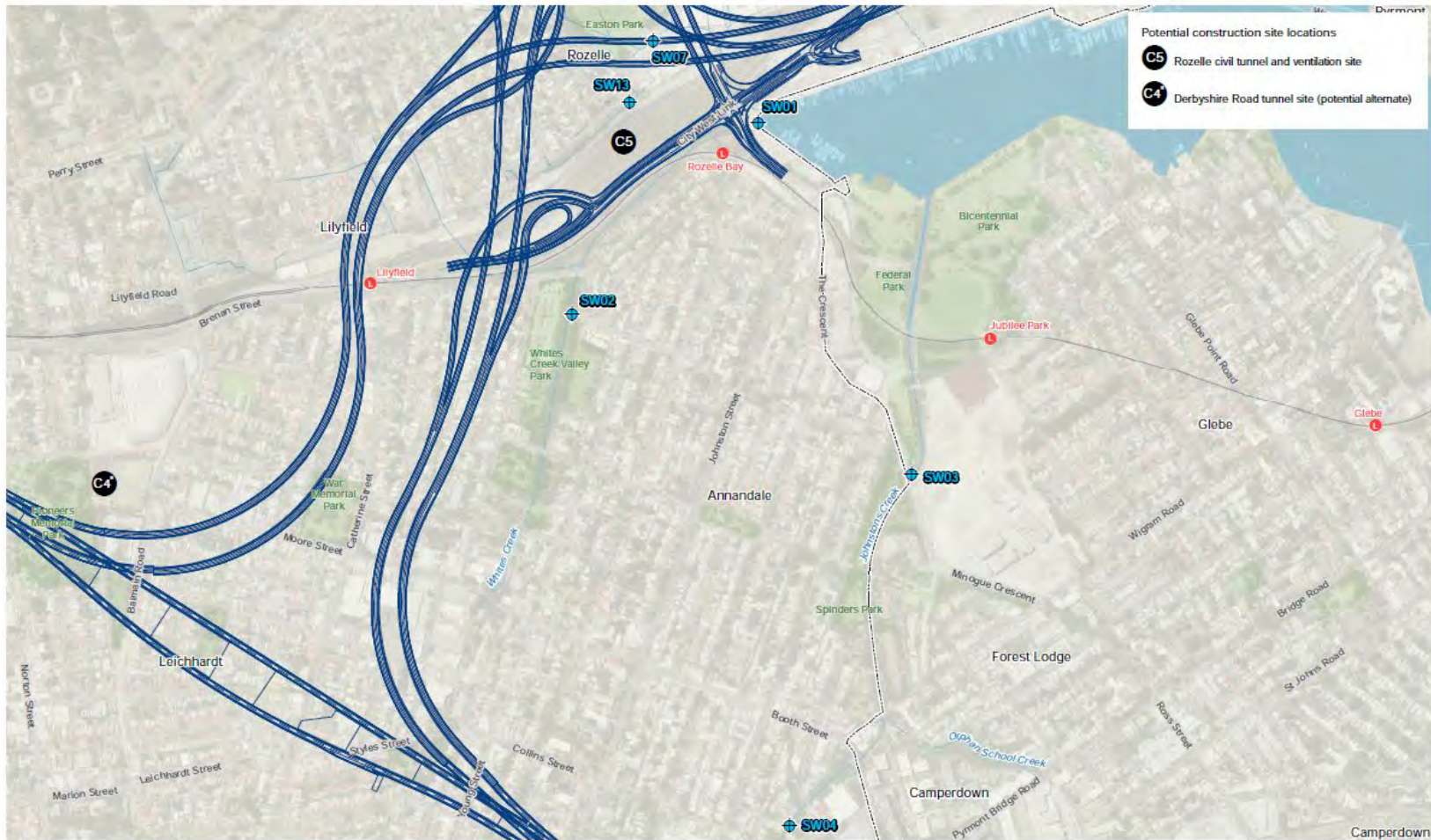

- KEY**
- Railway
 - Light rail
 - Light rail stop
 - Waterway
 - Local government area boundary
 - Parks, reserves and private recreation
 - M4-M5 Link
 - Surface water sampling locations

WestConnex
Building for the future



0 150 300m

This product is the property of AECOM and is not to be used for any other purpose without the written consent of AECOM. It is provided as a service to the client and is not to be used for any other purpose without the written consent of AECOM. It is provided as a service to the client and is not to be used for any other purpose without the written consent of AECOM.

Figure 1 Rozelle Interchange showing sampling locations (SW03 and SW04 will not be monitored for this project and are associated with the Mainline Tunnels Project)

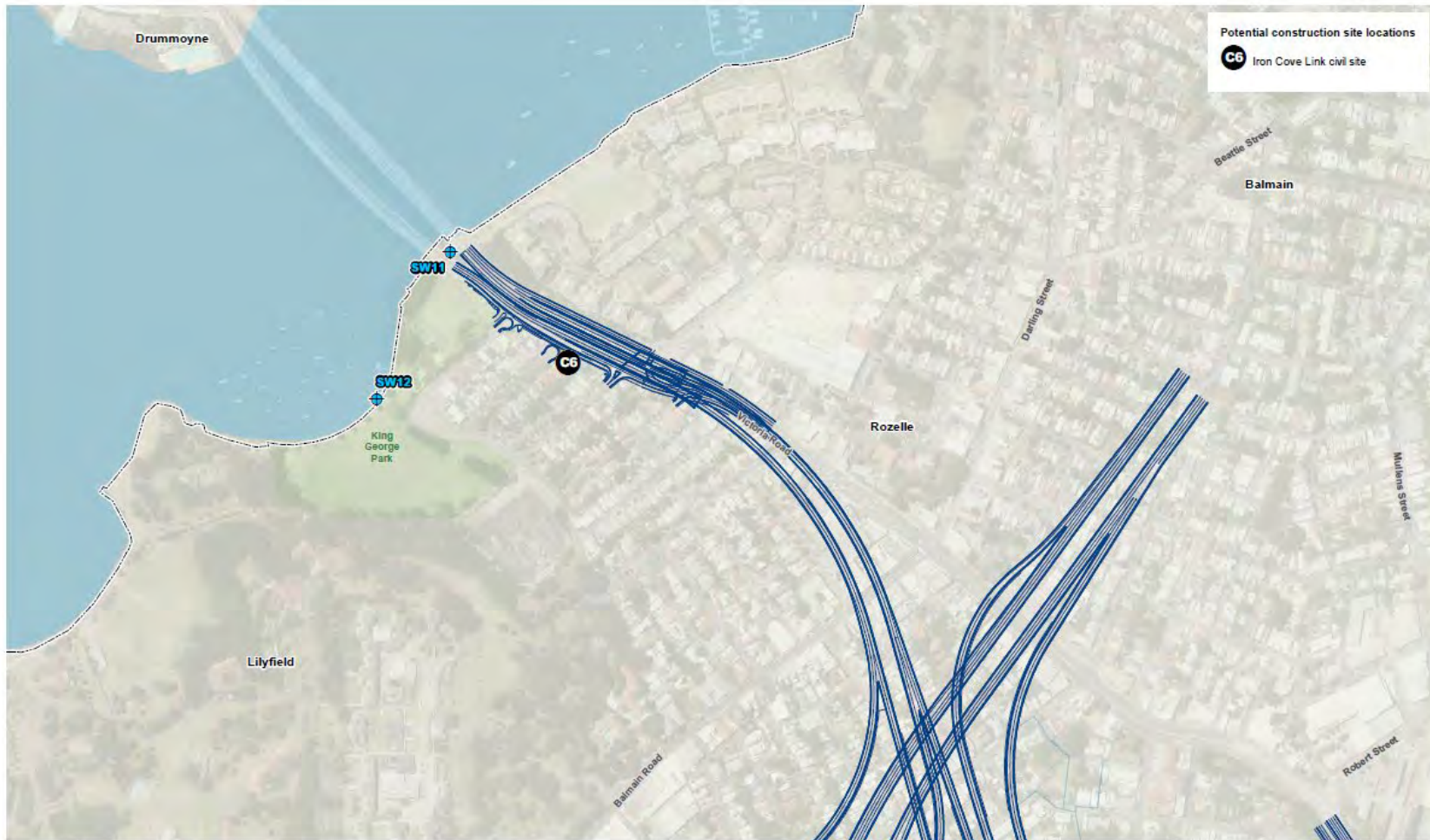

KEY
 Local government area boundary
 Parks, reserves and private recreation
 M4-M5 Link
 Surface water sampling locations

WestConnex
Building for the future

AECOM

0 30 180 m
 North arrow
 This plan was prepared by AECOM as part of the Sydney Harbour Tunnel
 Project. It is the property of AECOM and should not be used for any other purpose without the written consent of AECOM.
 AECOM makes no representation or warranty of any kind, and the accuracy, reliability, completeness, suitability or fitness for purpose, is not guaranteed.

Figure 2 Iron Cove Link showing sampling locations

3.1.3. Surface water quality

The baseline surface water quality sampling program (Table 2) included the following analytes:

- Physio-chemical (field) parameters (pH, temperature, electrical conductivity (EC), oxidation / reduction potential, dissolved oxygen, and turbidity),
- Benzene, toluene, ethylbenzene, xylene, and naphthalene (BTEXN),
- Dissolved metals (arsenic, cadmium, chromium, copper, iron, lead, manganese, mercury, nickel and zinc),
- Nutrients (nitrite as N, nitrate as N, reactive phosphorus and ammonia),
- Total recoverable hydrocarbons (TRHs), and
- Total petroleum hydrocarbons (TPHs).

Summary tables of the baseline water quality data are included in Annexure A. Interpretation of the baseline surface water monitoring data is included in the EIS (AECOM, 2017) and summarised in Table 3. The results are compared against the ANZECC (2000a) water quality guidelines. It should be noted that these guidelines are not to be used as a mandatory standard; rather they provide a guideline for the environmental values of water resources.

Table 2 Baseline surface water quality sampling program

Sample ID	Number of samples	Start of baseline monitoring	Minimum frequency
SW01	37	July 2016	Monthly
SW02	37	July 2016	Monthly
SW07	37	July 2016	Monthly
SW11	31	November 2016	Monthly
SW12	31	November 2016	Monthly

Table 3 Baseline water quality conditions in the Project area

Waterway	Baseline data obtained	Description of water quality
Rozelle Bay	Samples collected at SW01. Samples collected by The University of Sydney on behalf of UrbanGrowth NSW at BW1 as part of The Bays Precinct transformation project between July 2016 and June 2018.	Elevated concentrations of heavy metals (copper, chromium, lead and zinc), nitrogen, phosphorous, nitrate, oxides of nitrogen, ammonia and chlorophyll have been recorded. On some occasions the pH is outside guideline levels and the turbidity exceeds guideline levels.
Whites Creek	Samples collected at SW02. Samples collected by The University of Sydney on behalf of UrbanGrowth NSW within a tidally influenced location (at SW02) as part of The Bays Precinct transformation project between June and September 2016.	Elevated concentrations of heavy metals (chromium, copper, lead and zinc), phosphorus, nitrogen, nitrate and oxides of nitrogen were recorded. On some occasions the pH was outside guideline levels and the turbidity exceeds guideline levels.
Easton Park drain	Samples collected at SW07.	Elevated concentrations of heavy metals (copper, lead, and zinc) and nutrients (nitrogen phosphorus and nitrate) were recorded. On some occasions, the pH was outside guideline levels and the turbidity exceeded guideline levels.
Iron Cove	Samples collected at SW11 and SW12.	Elevated concentrations of metals (copper, chromium, lead, mercury and zinc), nitrogen, nitrate and phosphorous have been recorded.

Waterway	Baseline data obtained	Description of water quality
		Turbidity exceeds guideline values. The pH was outside guideline levels on occasions.
Open stormwater drain - Rozelle Rail Yards	Samples collected at SW13.	Elevated concentrations of metals (copper, chromium, lead, mercury and zinc), nitrogen, nitrate and phosphorous have been recorded. Turbidity exceeds guideline levels.

3.2. Surface water quality construction monitoring

3.2.1. Overview

The mobilisation of sediments and pollutants during the above-ground surface construction works and tunnelling is identified as a potential impact on surface water within the highly urbanised and disturbed catchments and waterways. A soil conservation specialist will be engaged to provide design input.

Table 5 contains the parameters to be tested as part of this Program. Site specific trigger values (SSTVs) are identified in Table 6 and will be used to assess potential impacts on sensitive receiving environments (Section 4.2.3 of SSWMP).

Variation in physio-chemical parameters (Table 6) provides an indication of a change to overall water quality triggering the assigned performance criteria and further impact assessment.

Groundwater inflows intercepted during tunnelling will be discharged via the Project WTP. The Project EPL may authorise discharge of water from specific locations or premises and establish criteria that differ from those given in this Program. In such circumstances the EPL, and any conditions and criteria of that EPL, take precedence over this Program. Discharged water quality will be monitored as detailed in the Project GWMP (in Section 4.3).

3.2.2. Rainfall monitoring

To provide data to assess water quality trends, rainfall will be monitored during the construction phase via a rain gauge at Rozelle Railyards, which will be checked on each workday or automated using an electronic weather station.

3.2.3. Monitoring locations

Surface water quality monitoring will be carried out during construction at six sites, listed in Table 4 and shown in Figure 1 and Figure 2. The monitoring program will commence prior to any ground disturbance in accordance with REMM SW02 (SSWMP Annexure A). Background monitoring commenced in July 2016 comprises the background monitoring of this program. Construction phase monitoring will commence following approval by DPE of this Program. The monitoring allows for the assessment trends in water quality, including natural variations, and will allow sufficient data to enable assessment of any potential impacts measured during construction. The surface water quality monitoring locations were also monitored during the baseline monitoring period that informed the EIS (as discussed in Section 3.1). Monitoring of discharge from the WTPs is discussed in the GWMP (Section 4.3).

Table 4 Construction phase surface water monitoring program

Sample ID ¹	Sample location	Ancillary Facility	Receiving environment	Analysis suite	Sampling frequency
SW01	Rozelle Bay (down-gradient)	Rozelle civil and tunnel site	Sydney Harbour/ Parramatta River	Physio-chemical parameters ²	Monthly/ Wet weather ³

Sample ID ¹	Sample location	Ancillary Facility	Receiving environment	Analysis suite	Sampling frequency
SW02	Whites Creek (up-gradient of Rozelle Interchange)	Rozelle civil and tunnel site	Sydney Harbour/ Parramatta River	Physio-chemical parameters ²	Monthly/ Wet weather ³
SW07	Easton Park drain (Up-gradient and down-gradient of construction)	Rozelle civil and tunnel site	Sydney Harbour/ Parramatta River	Physio-chemical parameters ²	Monthly/ Wet weather ³
SW11	Iron Cove (downstream)	Iron Cove civil and tunnel site	Sydney Harbour/ Parramatta River	Physio-chemical parameters ²	Monthly/ Wet weather ³
SW12	Iron Cove (downstream)	Iron Cove civil and tunnel site	Sydney Harbour/ Parramatta River	Physio-chemical parameters ²	Monthly/ Wet weather ³

Note:

1 Sample location ID's retained from EIS for consistency

2 Physico-chemical (field) parameter analysis as detailed in Table 5

3 Quarterly wet weather monitoring (at least once every 3 months following 25 mm of continuous rainfall – see Sampling frequency)

3.2.4. Sampling frequency

During the construction phase water quality sampling will be undertaken monthly.

Wet weather monitoring will be carried out (a minimum of once per 3 months where rainfall does not exceed 25mm) when a continuous rainfall event of >25 mm is received in the local catchment during a 24-hour period (as recorded at the Project's rain gauge(s) or nearby weather station) and has generated runoff from site.

For safety reasons sampling will not be undertaken during peak storm-flows. Sampling will be completed when flows are reasonably constant and monitoring points can be safely accessed, monitoring locations will be selected where possible to enable a safe monitoring location during all weather conditions.

The monitoring program will continue for the duration of construction and until the affected waterways are rehabilitated to an acceptable condition as certified by a suitably qualified and experienced independent expert.

3.2.5. Surface water quality parameters

Table 5 details the analytes that will be monitored during the construction phase surface water monitoring, at the locations listed in Table 4 and shown in Figure 1 and Figure 2.

Table 5 Surface water quality monitoring parameters

Category	Parameters ¹
Physico-chemical parameters	<ul style="list-style-type: none"> ▪ Temperature (°C) ▪ Dissolved Oxygen (mg/L) ▪ Electrical Conductivity (µS/cm) ▪ Reduction-Oxidation Potential (Redox)(mV) ▪ pH ▪ Total dissolved solids (TDS) ▪ Turbidity (NTU) ▪ Visible oil and grease

Note:

¹ Measured in the field using calibrated multi-probe water quality meter(s)

Surface water quality analysis results will be assessed and compared to baseline conditions, rainfall records, upstream monitoring results, and the performance criteria described below.

3.2.6. Performance criteria

Baseline monitoring shows that some surface water quality parameters exceed the default ANZECC (2000a) water quality trigger values for slightly to moderately disturbed ecosystems.

This is not unexpected given the highly urbanised and disturbed area and receiving waterways surrounding the project.

Location specific performance criteria (site-specific trigger values (SSTV)) have been developed for downstream (impact) surface water monitoring locations (see Table 6).

SSTV were developed for appropriate parameters using baseline monitoring data and ANZECC (2000a) guideline criteria for slightly to moderately disturbed ecosystems (generally protecting 90% of species) (Table 6).

- The 80th percentile of baseline data is used as the SSTV for those parameters/locations that exceeded the relevant ANZECC (2000a) guideline criteria. It is noted that exceedances of the ANZECC (2000a) guideline criteria are not unexpected due to the highly disturbed nature of the urban catchment area,
- The relevant ANZECC (2000a) guideline criteria is used as the SSTV for parameters where the 80th percentile of baseline data was below the relevant ANZECC (2000a) guideline criteria.

Table 6 Site specific trigger values

Parameter	Units	ANZECC guidelines	SW01	SW02	SW07	SW11	SW12	SW13
pH	pH	7.0-8.5	7.0-8.5	7.0-8.5	7.0-8.5	7.0-8.5	7.0-8.5	7.0-8.5
Electrical Conductivity	µS /cm	125 - 2,200	49,812	23,348	18,190	51,914	51,947	575
Turbidity	NTU	0.5 - 10	8.66	12.98	12.14	28.44	7.44	65.2

The SSTV's provide an easily identifiable indication of a potential change in water quality. A management response would be initiated if any of the following occurs:

- A parameter exceeds the SSTV for any single monitoring event by more than 30%,
- A parameter downstream exceeds the corresponding parameter upstream for any single monitoring event by more than 20%,
- A parameter exceeds the SSTV for two consecutive monthly monitoring events,
- A parameter exceeds the SSTV for half of the sampling events in a twelve-month period.

In the event that any of the above triggers are observed, a review will be initiated immediately to determine the significance of the exceedance(s) and possible causes. The review will assess the baseline data for the relevant waterway, recent rainfall records, other activities within the catchment and recent activities or recorded erosion/sediment control incidents occurring in the catchment.

If the exceedance is determined to be attributable to Project works, the event will be treated as an environmental incident and managed in accordance with the requirements of Section 3.10 of the CEMP. Corrective and preventative actions will be identified and implemented as part of that process.

4. Monitoring methodology / Sampling protocol

4.1. Sampling collection

Grab samples will be collected manually from the sampling locations identified in Table 4, Figure 1 and Figure 2. The volume of sample collected will be sufficient for the required physio-chemical (field) parameter analysis using a multi-probe water quality meter(s).

4.2. Field measures

Field physico-chemical parameters including EC, pH, DO, TDS, ORP, temperature, and turbidity will be measured at each sampling location using a fully calibrated multi-probe water quality meter(s) or provided for laboratory analysis. Other observations including odour and colour may also be recorded.

The multi-probe field water quality meter(s) will be calibrated against known standards, as supplied by the manufacturer, at the start and completion of each day of water quality sampling.

4.3. Recording of field results

Results for each monitoring location will be recorded on appropriate field sheets (hard copy or digital) using unique sampling identification nomenclature consisting of the sample date, location, and sampler details.

4.4. Decontamination

Sampling equipment will be cleaned (decontaminated) between each sample. Where a sample site shows evidence of contamination (i.e. there is an algal bloom, or the site smells strongly of hydrocarbons, sewage or something else) equipment will need to be cleaned thoroughly. In addition, equipment will need to be cleaned periodically to prevent a build-up of dirt.

The following method will be followed:

- Rinse the equipment in tap water,
- Clean with De-Con 90 (a phosphate free detergent), or equivalent,
- Rinse again with tap water,
- Rinse three times with de-ionised water; and
- Allow to dry.

De-ionised and tap water will be available for washing equipment in the field, if required.

4.5. Quality Assurance and documentation

Any sample to be sent to a laboratory will be subject to quality assurance protocols.

Quality assurance and control protocols during sampling and recording of physio-chemical (field) parameters will be undertaken monthly (each sampling event) in accordance with ANZECC/ARMCANZ (2000b) to ensure the integrity of the dataset.

As part of sampling the following will be undertaken:

- Rinsate blanks (one per sampling event only),
- Blind duplicates (at a rate not less than 20% of total samples), and
- Split duplicates (at a rate not less than 20% of total samples).

Samples are to be transported to a NATA-accredited laboratory under documented chain-of-custody protocols.

Field results will be checked for accuracy before leaving the site and errors or discrepancies will be cross-checked, and further investigation initiated if required.

Monitoring and calibration records will be maintained in accordance with the appropriate standard.

5. Compliance management

5.1. Roles, responsibility, and training

The JHCPB Project Team's organisational structure and overall roles and responsibilities are outlined in Section 3.3 of the CEMP. Specific responsibilities for the implementation of environmental controls are detailed in the SWMP.

All employees, contractors and utility staff working on site will undergo site induction and targeted training relating to surface water management issues, detailed in the SWMP.

Further details regarding staff induction and training are outlined in Section 3.5 of the CEMP.

5.2. Monitoring and inspection

This Program details the monitoring requirements for surface water. Additional soil and surface water inspection requirements (including weekly site inspections) are detailed in the SSWMP Section 7.3.

In accordance with Section 3.3.1 of the CEMP, JHCPB Environmental and Sustainability Manager will be responsible for ensuring monitoring activities are undertaken.

Additional requirements and responsibilities in relation to inspections are documented in Section 3.9.2 of the CEMP.

5.3. Data analysis and management response

Results from the construction monitoring program will be compared with the SSTVs and with previous results.

Monthly monitoring results for surface water quality will be compared against SSTVs (Table 6), and reported in the construction compliance monitoring reports (Section 5.5). If a trigger is observed (see Section 3.2.6), a review will be initiated to determine the significance of the exceedance(s) and possible causes. The review will assess available surface water data, baseline data for the relevant waterway, recent rainfall records, and recent activities or recorded erosion/sediment control incidents occurring in the catchment. If the exceedance is determined to be attributable to Project works, the event will be treated as an environmental incident and managed in accordance with the requirements of the CEMP. Corrective and preventative actions will be identified and implemented as part of that process.

5.4. Auditing

Audits (both internal and external) will be undertaken to assess the effectiveness of environmental controls, compliance with this Program, CoA, and other relevant approvals, licenses and guidelines.

Audit requirements are detailed in Section 3.9.3 of the CEMP.

5.5. Reporting

During construction, surface water quality data will be collected, tabulated and assessed against baseline conditions and performance criteria. Monitoring reports will be submitted to DPIE, EPA, DoI Water and Sydney Water within 30 days of the reporting period unless otherwise agreed with DPIE.

Reporting requirements associated with the Program for the construction phase of the Project are presented in Table 7.

Table 7 Reporting requirements

Schedule (during construction)	Requirements	Recipient (relevant authority)
Water Monitoring Reports (every six months)	Data summary reports presenting tabulated surface water monitoring data collected during the reporting period. Surface water quality results will be presented and performance criteria exceedances will be highlighted. Applicable management responses will be documented.	EPA, DPE, DoI Water, Sydney Water
EPL Monitoring Reports and Annual Returns	EPL monitoring reports will be prepared in accordance with the requirements of the EPL. An EPL Annual Return will be prepared in respect of each EPL reporting period (typically 12 months).	EPA
Construction Compliance Reports (every six months)	A results summary an analysis of environmental monitoring.	DPE, RMS, ER
Monthly Environmental Report (every month)	Monitoring program performance will be documented in the Monthly Environmental Report. Any incidents and key environmental issues will be documented.	RMS

6. Review and improvement

6.1. Continuous improvement

Monitoring data will be reviewed throughout the construction period to provide potential requirements to increase, or decrease, the number of sampling locations and/or the analytical suites. SSTV will be reviewed for appropriateness following 12 months of construction monitoring. Alterations to SSTV, monitoring locations, analytical suites, or frequencies will be reported in the Water Monitoring Reports (Section 5.5).

Continuous improvement of this Program will be achieved by the ongoing evaluation of environmental management performance against environmental policies, objectives and targets (detailed in Section 2.2), and the Project performance outcomes of the EIS for the purpose of identifying opportunities for improvement.

The continuous improvement process will be designed to:

- Identify areas of opportunity for improvement of environmental management and performance,
- Determine the cause or causes of non-conformances and deficiencies,
- Develop and implement a plan of corrective and preventative action to address any non-conformances and deficiencies,
- Verify the effectiveness of the corrective and preventative actions,
- Document any changes in procedures resulting from process improvement, and
- Make comparisons with objectives and targets.

6.2. SWQMP update and amendment

The processes described in Section 3.13.1 and Section 3.13.2 of the CEMP may result in the need to update or revise this Program.

Revisions of this Program will be in accordance with the process outlined in Section 3.13.1 of the CEMP.

A copy of the updated Program and changes will be distributed to all relevant stakeholders in accordance with the approved document control procedure – refer to Section 3.11.2 of the CEMP.

7. References

- Acid Sulfate Soil Management Advisory Committee (ASSMAC), 1998. Acid Sulfate Soil Manual
- AECOM, 2017. WestConnex M4-M5 EIS Technical Working Paper: Surface Water and Flooding, August 2017.
- ANZECC/ARMCANZ, 2000a. Australian and New Zealand Guidelines for Fresh and Marine Water Quality
- ANZECC/ARMCANZ, 2000b. Australian Guidelines for Water Quality Monitoring and Reporting.
- EPA, 2004. Approved Methods for the Sampling and Analysis of Water Pollutants in NSW.
- Landcom, 2004. Managing Urban Stormwater: Soils and Construction. Landcom, (4th Edition) March 2004 (reprinted 2006) (the "Blue Book"). Volume 1 and Volume 2.
- NSW Department of Conservation and Land Management, 1989. Soil Landscapes of the Sydney 1:100,000 Sheet 9130
- NSW Department of Infrastructure, Planning and Natural Resources, 2002. Salinity Potential in Western Sydney Map
- RTA, 1999. Guideline for Construction Water Quality Monitoring. NSW Road and Traffic Authority

Annexure A Baseline surface water monitoring results

Baseline Surface Water Monitoring SW01						
Parameter	Units	Count	mean	min	max	80th percentile
Physiochemical Parameters						
Turbidity	NTU	33	5.89	0	52	8.66
pH	-	37	7.49	5.65	8.04	7.904
EC	µS/cm	37	40433.89	403	541180	49812.4
Temp	0C	37	20.74	15.7	28	24.68
DO	Mg/L	37	23.63	-0.16	558	6.656
Redox	mV	37	393.84	209.7	3980	387.04
Chemical analytes						
Ammonia as N	µg/L	3	245	70	240	-
Kjeldahl Nitrogen Total	mg/L	31	3.8	0.2	41.4	1.44
Nitrite (as N)	mg/L	31	0.03	0.01	0.04	0.04
Nitrogen (Total Oxidised)	mg/L	29	0.27	0.01	1.82	0.46
Nitrogen (Total)	mg/L	31	4315	300	41500	2240
Reactive Phosphorus as P	mg/L	31	0.027	0.01	0.08	0.04
Phosphorus (Total)	mg/L	31	0.30	0.02	3.76	0.17
Arsenic	mg/L	34	0.04	0.0013	0.42	0.0892
Cadmium	mg/L	34	0.0018	0.0001	0.006	0.00284
Chromium	mg/L	34	0.00167	0.0004	0.0064	0.00202
Chromium (III+VI)	mg/L	-	-	-	-	-
Copper	mg/L	28	0.010627	0.002	0.0586	0.0134
Ferrous Iron	mg/L	31	0.35	0.05	2.94	0.388
Iron	mg/L	33	0.3965	0.005	4.01	0.353
Lead	mg/L	34	0.0369054	0.0009	6.64	0.11208
Manganese	mg/L	33	0.021821429	0.0012	0.121	0.02484
Mercury	mg/L	34	0.021309	0.00006	0.0422	0.03674
Nickel	mg/L	34	0.44395	0.000008	1	0.00176
Zinc	mg/L	34	0.089169	0.0008	0.053	0.094

Baseline Surface Water Monitoring SW01						
Benzene	µg/L	34	0.5	0.5	0.5	0.5
Ethylbenzene	µg/L	34	1	1	1	1
Toluene	µg/L	34	1	1	1	1
Xylene (m & p)	µg/L	34	1	1	1	1
Xylene (o)	µg/L	34	1	1	1	1
Xylene Total	µg/L	34	1	1	1	1
Naphthalene	µg/L	34	2.5	2.5	2.5	2.5
C6-C10	mg/L	34	0.01	0.01	0.01	0.01
C6-C10 less BTEX (F1)	mg/L	34	0.01	0.01	0.01	0.01
F2-NAPHTHALENE	mg/L	34	0.05	0.05	0.05	0.05
C10-C16	mg/L	34	0.05	0.05	0.05	0.05
C16-C34	mg/L	34	0.05	0.05	0.05	0.05
C34-C40	mg/L	34	0.05	0.05	0.05	0.05
C10-C40 (Sum of total)	mg/L	34	0.05	0.05	0.05	0.05
C6-C9	mg/L	34	0.01	0.01	0.01	0.01
C10-C14	mg/L	34	0.025	0.025	0.025	0.025
C15-C28	mg/L	34	0.05	0.05	0.05	0.05
C29-C36	mg/L	34	0.025	0.025	0.025	0.025
+C10-C36 (Sum of Total)	mg/L	34	0.025	0.025	0.025	0.025

Baseline Surface Water Monitoring SW02						
Parameter	Units	Count	mean	min	max	80th percentile
Physiochemical Parameters						
Turbidity	NTU	33	20.8	0	430.7	12.98
pH	-	37	7.92	5.38	9.49	8.592
EC	µS/cm	37	8955.027	268	51935	23348
Temp	0C	37	20.11	13	32.5	23.27
DO	Mg/L	37	13.06	2.67	74.5	13.948
Redox	mV	36	335.61	211	584	373.24
Chemical analytes						
Ammonia as N	µg/L	3	190	30	480	-
Kjeldahl Nitrogen Total	mg/L	32	0.13	0.2	1.3	0.8
Nitrite (as N)	mg/L	32	0.8109375	<0.01	0.18	0.13
Nitrogen (Total Oxidised)	mg/L	32	0.88	0.02	2.76	1.11
Nitrogen (Total)	mg/L	32	1543	300	3600	2000
Reactive Phosphorus as P	mg/L	32	0.04	0.01	0.012	0.056
Phosphorus (Total)	mg/L	32	0.09	0.02	0.48	0.134
Arsenic	mg/L	36	0.001172414	0.0005	0.003	0.0016
Cadmium	mg/L	36	0.000162	0.0001	0.00033	0.0002
Chromium	mg/L	36	0.002133	0.0004	0.0056	0.00364
Chromium (III+VI)	mg/L	-	-	-	-	-
Copper	mg/L	36	0.011	0.003	0.119	0.0098
Ferrous Iron	mg/L	32	0.13	0.05	0.62	0.178
Iron	mg/L	35	0.42	0.134	1.15	0.058
Lead	mg/L	36	0.0071	0.0008	0.055	0.0116
Manganese	mg/L	35	0.019	0.006	0.06	0.027
Mercury	mg/L	36	2.93333E-05	0.0000019	0.000049	0.000049
Nickel	mg/L	36	0.00144	0.0006	0.003	0.00196
Zinc	mg/L	36	0.08275	0.017	0.361	0.1362
Benzene	µg/L	36	0.5	0.5	0.5	0.5
Ethylbenzene	µg/L	36	1	1	1	1
Toluene	µg/L	36	1	1	1	1

Baseline Surface Water Monitoring SW02						
Xylene (m & p)	µg/L	36	1	1	1	1
Xylene (o)	µg/L	36	1	1	1	1
Xylene Total	µg/L	36	1	1	1	1
Naphthalene	µg/L	36	2.5	2.5	2.5	2.5
C6-C10	mg/L	36	0.01	0.01	0.01	0.01
C6-C10 less BTEX (F1)	mg/L	36	0.01	0.01	0.01	0.01
F2-NAPHTHALENE	mg/L	36	0.05	0.05	0.05	0.05
C10-C16	mg/L	36	0.05	0.05	0.05	0.05
C16-C34	mg/L	36	0.05	0.05	0.05	0.05
C34-C40	mg/L	36	0.05	0.05	0.05	0.05
C10-C40 (Sum of total)	mg/L	36	0.05	0.05	0.05	0.05
C6-C9	mg/L	36	0.01	0.01	0.01	0.01
C10-C14	mg/L	36	0.025	0.025	0.025	0.025
C15-C28	mg/L	36	0.05	0.05	0.05	0.05
C29-C36	mg/L	36	0.025	0.025	0.025	0.025
+C10-C36 (Sum of Total)	mg/L	36	0.025	0.025	0.025	0.025

Baseline Surface Water Monitoring SW07						
Parameter	Units	Count	mean	min	max	80th percentile
Physiochemical Parameters						
Turbidity	NTU	33	24.19	0	390.7	12.14
pH	-	37	7.89	5.87	10.06	8.584
EC	µS/cm	37	8124.39	200	50618	18190
Temp	0C	37	19.23	13.9	25.3	22.54
DO	Mg/L	37	8.32	1.94	12.58	10.314
Redox	mV	37	333.34	126	625	378.36
Chemical analytes						
Ammonia as N	µg/L	7	372.86	50	1640	890
Kjeldahl Nitrogen Total	mg/L	36	1.34	<0.1	5.9	1.88
Nitrite (as N)	mg/L	36	<0.041	<0.01	0.13	0.06
Nitrogen (Total Oxidised)	mg/L	30	1.809333333	0.02	4.17	2.54
Nitrogen (Total)	mg/L	36	3080	800	6300	4160
Reactive Phosphorus as P	mg/L	36	0.07	0.01	0.23	0.11
Phosphorus (Total)	mg/L	36	0.21	<0.1	1.28	0.294
Arsenic	mg/L	37	0.0026	0.0006	0.006	0.004
Cadmium	mg/L	37	0.000162	0.0001	0.00033	0.0002
Chromium	mg/L	37	0.002133	0.0004	0.0056	0.00364
Chromium (III+VI)	mg/L	-	-	-	-	-
Copper	mg/L	37	0.016008	<0.01	0.054	0.0186
Ferrous Iron	mg/L	36	0.238	<0.05	1.28	0.326
Iron	mg/L	35	0.91	0.11	4.16	1.8
Lead	mg/L	37	0.027	0.001	0.164	0.0446
Manganese	mg/L	36	0.024	0.0041	0.072	0.038
Mercury	mg/L	37	0.00000725	0.000005	0.00001	0.00001
Nickel	mg/L	37	0.005380556	0.0009	0.014	0.00792
Zinc	mg/L	37	0.17	0.038	0.4	0.25
Benzene	µg/L	37	0.5	0.5	0.5	0.5
Ethylbenzene	µg/L	37	1	1	1	1
Toluene	µg/L	37	1	1	1	1

Baseline Surface Water Monitoring SW07						
Xylene (m & p)	µg/L	37	1	1	1	1
Xylene (o)	µg/L	37	1	1	1	1
Xylene Total	µg/L	37	1	1	1	1
Naphthalene	µg/L	37	2.5	2.5	2.5	2.5
C6-C10	mg/L	37	0.01	0.01	0.01	0.01
C6-C10 less BTEX (F1)	mg/L	37	0.01	0.01	0.01	0.01
F2-NAPHTHALENE	mg/L	37	0.05	0.05	0.05	0.05
C10-C16	mg/L	37	0.05	0.05	0.05	0.05
C16-C34	mg/L	37	0.05	0.05	0.05	0.05
C34-C40	mg/L	37	0.05	0.05	0.05	0.05
C10-C40 (Sum of total)	mg/L	37	0.05	0.05	0.05	0.05
C6-C9	mg/L	37	0.01	0.01	0.01	0.01
C10-C14	mg/L	37	0.025	0.025	0.025	0.025
C15-C28	mg/L	37	0.05	0.05	0.05	0.05
C29-C36	mg/L	37	0.025	0.025	0.025	0.025
+C10-C36 (Sum of Total)	mg/L	37	0.025	0.025	0.025	0.025

Baseline Surface Water Monitoring SW11						
Parameter	Units	Count	mean	min	max	80th percentile
Physiochemical Parameters						
Turbidity	NTU	27	39.37778	0	647	28.44
pH	-	31	7.865161	6.56	8.29	8.066
EC	µS/cm	31	45142.81	3565	54337	51914
Temp	0C	31	20.62258	13.6	27.2	24.04
DO	Mg/L	31	6.577742	-0.76	9.71	7.692
Redox	mV	31	313.029	62.5	456.1	376.8
Chemical analytes						
Ammonia as N	µg/L	7	60	40	110	86
Kjeldahl Nitrogen Total	mg/L	31	0.05	0.05	0.05	0.05
Nitrite (as N)	mg/L	31	0.01	0.01	0.02	0.01
Nitrogen (Total Oxidised)	mg/L	25	0.11	0.01	0.48	0.17
Nitrogen (Total)	mg/L	31	1500	700	3900	3360
Reactive Phosphorus as P	mg/L	31	0.023	0.01	0.08	0.03
Phosphorus (Total)	mg/L	31	0.311	0.06	1.3	0.682
Arsenic	mg/L	32	0.00258	0.0014	0.006	0.00344
Cadmium	mg/L	32	0.0002	0.001	0.00021	0.0002
Chromium	mg/L	32	0.002772	0.0006	0.0117	0.00512
Chromium (III+VI)	mg/L	-	-	-	-	-
Copper	mg/L	32	0.006815	0.002	0.029	0.0104
Ferrous Iron	mg/L	32	0.15	0.06	0.046	0.198
Iron	mg/L	31	0.7815	0.015	3.97	1.398
Lead	mg/L	32	0.01033	0.0002	0.0622	0.01692
Manganese	mg/L	31	0.021	0.0054	0.0829	0.0344
Mercury	mg/L	32	0.000103	0.000007	0.00035	0.00016
Nickel	mg/L	32	0.001088889	0.0006	0.0028	0.00148
Zinc	mg/L	32	0.025692	0.007	0.106	0.0376
Benzene	µg/L	32	0.5	0.5	0.5	0.5
Ethylbenzene	µg/L	32	1	1	1	1
Toluene	µg/L	32	1	1	1	1

Baseline Surface Water Monitoring SW11						
Xylene (m & p)	µg/L	32	1	1	1	1
Xylene (o)	µg/L	32	1	1	1	1
Xylene Total	µg/L	32	1	1	1	1
Naphthalene	µg/L	32	2.5	2.5	2.5	2.5
C6-C10	mg/L	32	0.01	0.01	0.01	0.01
C6-C10 less BTEX (F1)	mg/L	32	0.01	0.01	0.01	0.01
F2-NAPHTHALENE	mg/L	32	0.05	0.05	0.05	0.05
C10-C16	mg/L	32	0.05	0.05	0.05	0.05
C16-C34	mg/L	32	0.05	0.05	0.05	0.05
C34-C40	mg/L	32	0.05	0.05	0.05	0.05
C10-C40 (Sum of total)	mg/L	32	0.05	0.05	0.05	0.05
C6-C9	mg/L	32	0.01	0.01	0.01	0.01
C10-C14	mg/L	32	0.025	0.025	0.025	0.025
C15-C28	mg/L	32	0.05	0.05	0.05	0.05
C29-C36	mg/L	32	0.025	0.025	0.025	0.025
+C10-C36 (Sum of Total)	mg/L	32	0.025	0.025	0.025	0.025

Baseline Surface Water Monitoring SW12						
Parameter	Units	Count	mean	min	max	80th percentile
Physiochemical Parameters						
Turbidity	NTU	28	4.017857	-0.2	15	7.44
pH	-	31	7.826452	7.32	8.26	8.024
EC	µS/cm	31	44428.03	465	54271	51947
Temp	0C	31	20.85806	14.4	26.5	24.44
DO	Mg/L	31	5.714194	-1.22	8.52	7.144
Redox	mV	31	268.5484	101.3	479.5	352.44
Chemical analytes						
Ammonia as N	µg/L	8	<5	<0.001	160	<5
Kjeldahl Nitrogen Total	mg/L	32	17.11	0.5	200	1
Nitrite (as N)	mg/L	32	0.21	0.01	0.87	0.01
Nitrogen (Total Oxidised)	mg/L	32	0.0264	0.01	1.1	
Nitrogen (Total)	mg/L	32	664	0.04	1900	1260
Reactive Phosphorus as P	mg/L	32	0.041	0.01	0.25	0.04
Phosphorus (Total)	mg/L	32	133.61	0.03	1200	1.09
Arsenic	mg/L	31	0.00222	0.0014	0.005	0.00238
Cadmium	mg/L	31	0.000331	0.0001	0.0006	0.00054
Chromium	mg/L	31	0.001771	0.0005	0.013	0.0012
Chromium (III+VI)	mg/L	-	-	-	-	
Copper	mg/L	31	0.005092	0.001	0.016	0.00628
Ferrous Iron	mg/L	31	25.12	0.05	160	66
Iron	mg/L	30	0.45	0.036	5.43	0.4126
Lead	mg/L	31	0.005723	0.0003	0.-63	0.00456
Manganese	mg/L	30	0.01947	0.0049	0.068	0.03012
Mercury	mg/L	31	0.0001356	0.000007	0.0006	0.00049
Nickel	mg/L	31	0.005377	0.0005	0.0502	0.0062
Zinc	mg/L	31	0.055815	0.01	0.306	0.0986
Benzene	µg/L	31	0.5	0.5	0.5	0.5
Ethylbenzene	µg/L	31	1	1	1	1
Toluene	µg/L	31	1	1	1	1

Baseline Surface Water Monitoring SW12						
Xylene (m & p)	µg/L	31	1	1	1	1
Xylene (o)	µg/L	31	1	1	1	1
Xylene Total	µg/L	31	1	1	1	1
Naphthalene	µg/L	31	2.5	2.5	2.5	2.5
C6-C10	mg/L	31	0.01	0.01	0.01	0.01
C6-C10 less BTEX (F1)	mg/L	31	0.01	0.01	0.01	0.01
F2-NAPHTHALENE	mg/L	31	0.05	0.05	0.05	0.05
C10-C16	mg/L	31	0.05	0.05	0.05	0.05
C16-C34	mg/L	31	0.05	0.05	0.05	0.05
C34-C40	mg/L	31	0.05	0.05	0.05	0.05
C10-C40 (Sum of total)	mg/L	31	0.05	0.05	0.05	0.05
C6-C9	mg/L	31	0.01	0.01	0.01	0.01
C10-C14	mg/L	31	0.025	0.025	0.025	0.025
C15-C28	mg/L	31	0.05	0.05	0.05	0.05
C29-C36	mg/L	31	0.025	0.025	0.025	0.025
+C10-C36 (Sum of Total)	mg/L	31	0.025	0.025	0.025	0.025

Baseline Surface Water Monitoring SW13						
Parameter	Units	Count	mean	min	max	80th percentile
Physiochemical Parameters						
Turbidity	NTU	23	63.53913	0	726.5	65.2
pH	-	27	7.733333	6.8	9.9	8.294
EC	µS/cm	27	530.0741	86	3879	575.2
Temp	0C	27	17.72222	9.3	23.4	20.96
DO	Mg/L	27	5.22	0.13	46.68	5.464
Redox	mV	28	254.2143	0	405	358.7
Chemical analytes						
Ammonia as N	µg/L	3	290	70	510	-
Kjeldahl Nitrogen Total	mg/L	27	3.988461538	0.3	37	4.48
Nitrite (as N)	mg/L	27	0.023	0.01	0.04	0.03
Nitrogen (Total Oxidised)	mg/L	22	0.267	0.01	1.07	0.462
Nitrogen (Total)	mg/L	27	4285	300	37,000	4700
Reactive Phosphorus as P	mg/L	27	0.083846154	0.01	0.46	0.116
Phosphorus (Total)	mg/L	27	1.1164	0.08	6.93	1.852
Arsenic	mg/L	27	0.013985	0.0015	0.103	0.017
Cadmium	mg/L	27	0.002784	0.00019	0.0123	0.00564
Chromium	mg/L	27	0.005687	0.0004	0.048	0.00564
Chromium (III+VI)	mg/L	-	-	-	-	-
Copper	mg/L	27	0.033737	0.0013	0.288	0.0408
Ferrous Iron	mg/L	27	3.01	0.09	22.1	3.4
Iron	mg/L	22	9.3607	0.219	50.6	16.46
Lead	mg/L	27	0.078067	0.0022	0.6	0.1314
Manganese	mg/L	23	1.042326	0.037	8.3	1.056
Mercury	mg/L	27	7.05556E-05	0.000005	0.0002	0.0001
Nickel	mg/L	27	0.005619	0.001	0.021	0.0096
Zinc	mg/L	27	1.263	0.083	5.62	2.628
Benzene	µg/L	27	0.5	0.5	0.5	0.5
Ethylbenzene	µg/L	27	1	1	1	1
Toluene	µg/L	27	1	1	1	1

Baseline Surface Water Monitoring SW13						
Xylene (m & p)	µg/L	27	1	1	1	1
Xylene (o)	µg/L	27	1	1	1	1
Xylene Total	µg/L	27	1	1	1	1
Naphthalene	µg/L	27	2.5	2.5	2.5	2.5
C6-C10	mg/L	27	0.01	0.01	0.01	0.01
C6-C10 less BTEX (F1)	mg/L	27	0.01	0.01	0.01	0.01
F2-NAPHTHALENE	mg/L	27	0.05	0.05	0.05	0.05
C10-C16	mg/L	27	0.05	0.05	0.05	0.05
C16-C34	mg/L	27	0.05	0.05	0.05	0.05
C34-C40	mg/L	27	0.05	0.05	0.05	0.05
C10-C40 (Sum of total)	mg/L	27	0.05	0.05	0.05	0.05
C6-C9	mg/L	27	0.01	0.01	0.01	0.01
C10-C14	mg/L	27	0.025	0.025	0.025	0.025
C15-C28	mg/L	27	0.05	0.05	0.05	0.05
C29-C36	mg/L	27	0.025	0.025	0.025	0.025
+C10-C36 (Sum of Total)	mg/L	27	0.025	0.025	0.025	0.025

ANZECC (2000a) water quality guidelines

Parameter	Units	South-east Australia default triggers			Freshwater		Marine	
		NSW Lowland Rivers	Estuarine	Recreation	99% Protection	95% Protection	99% Protection	95% Protection
Turbidity	NTU	6-50	0.5-10					
pH	-	6.5-8.5	7.0-8.5	6.5-8.5				
EC	µS/cm	125-2,200						
Temp	0C							
DO	Mg/L							
Redox	mV							
Chemical analytes								
Ammonia as N	µg/L	20	15	10	320	900	500	910
Kjeldahl Nitrogen Total	mg/L							
Nitrite (as N)	mg/L							
Nitrogen (Total Oxidised)	mg/L	0.04	0.015	10/1				
Nitrogen (Total)	mg/L	0.35	0.3					
Reactive Phosphorus as P	mg/L	0.02	0.005					
Phosphorus (Total)	mg/L	0.025	0.03					
Arsenic	mg/L			0.05	0.001/0.0008	0.024/0.013	ID	ID
Cadmium	mg/L			0.005	0.00006	0.0002	0.0007	0.0055
Chromium	mg/L			0.05	ID/0.00001	ID/0.001	0.008/0.00014	0.027/0.0044
Chromium (III+VI)	mg/L							
Copper	mg/L			1	0.0010	0.0014	0.0003	0.0013
Ferrous Iron	mg/L			0.3	ID	ID	ID	ID
Iron	mg/L			0.3	ID	ID	ID	ID
Lead	mg/L			0.05	0.001	0.0034	0.0022	0.0044
Manganese	mg/L			0.1	1.2	1.9	ID	ID
Mercury	mg/L			0.001	0.00006	0.0006	0.0001	0.0004

Parameter	Units	South-east Australia default triggers			Freshwater		Marine	
		NSW Lowland Rivers	Estuarine	Recreation	99% Protection	95% Protection	99% Protection	95% Protection
Nickel	mg/L			0.1	0.008	0.011	0.007	0.015
Zinc	mg/L			5	0.0024	0.008	0.007	0.015
Benzene	µg/L			10	600	950	500	700
Ethylbenzene	µg/L				ID	ID	ID	ID
Toluene	µg/L				ID	ID	ID	ID
Xylene (m & p)	µg/L				ID	ID	ID	ID
Xylene (o)	µg/L				200	350	ID	ID
Xylene Total	µg/L							
Naphthalene	µg/L				2.5	16	50	70
C6-C10	mg/L							
C6-C10 less BTEX (F1)	mg/L							
F2-NAPHTHALENE	mg/L							
C10-C16	mg/L							
C16-C34	mg/L							
C34-C40	mg/L							
C10-C40 (Sum of total)	mg/L							
C6-C9	mg/L							
C10-C14	mg/L							
C15-C28	mg/L							
C29-C36	mg/L							
+C10-C36 (Sum of Total)	mg/L							

Annexure C Contaminated Land Management Plan

JHCPB Joint Venture

Contaminated Land Management Plan

RIC-JHC-MPL-00-PL-270-003

Project	Design and Construction of Rozelle Interchange and Western Harbour Tunnel Enabling Works Project
Design Lot No.	00-PL-270
Document No.	RIC-JHC-MPL-00-PL-270-003
Revision Date	02 May 2019

Document Approval

Rev	Date	Prepared by	Reviewed by	Approved by	Remarks
A	27/03/2019	██████████	██████████		██████████
B	05/04/2019	██████████	██████████		██████████
00	02/05/2019	██████████	██████████		For submission to DPE

Contents

1. Introduction.....	5
2. Purpose and objectives.....	5
2.1. Purpose.....	5
2.2. Objectives	5
2.3. Environmental Performance Outcomes and Targets	5
3. Environmental Requirements.....	6
3.1. Relevant legislation and guidelines	6
3.1.1. Legislation	6
3.1.2. Guidelines and standards	6
4. Existing Environment	8
4.1. Previous investigations.....	8
4.2. Further investigations	9
5. Environmental aspects and impacts.....	10
5.1. Construction activities	10
5.2. Impacts	10
6. Environmental control measures.....	14
6.1. Contamination Management Process.....	14
6.1.1. Phase 1 Environmental Site Assessment.....	14
6.1.2. Phase 2 Sampling, Analytical and Quality Plan.....	14
6.1.3. Phase 2 Environmental Site Assessment.....	14
6.1.4. Remediation Action Plan.....	15
6.1.5. Remediation Validation Report	15
6.1.6. Long Term Environmental Management Plan	16
6.1.7. Site Audit Report and Site Audit Statements.....	16
6.2. Management strategies	17
6.3. General environmental safeguards.....	18
7. Compliance management	23
7.1. Roles and responsibilities.....	23
7.2. Training.....	23
7.3. Monitoring and inspections.....	23
7.4. Auditing.....	24
7.5. Reporting.....	24
8. Review and improvement.....	25
8.1. Continuous improvement.....	25
8.2. CLMP update and amendment.....	25

Table of Tables

Table 1: Performance outcomes	5
Table 2: Potential contaminants of concern.....	8
Table 3: Risk assessment for potential construction impacts	11
Table 4: Project controls for contamination management.....	17
Table 5: Contaminated land management and mitigation measures	18
Table 6: Reporting requirements relevant to contamination management.....	23
Table 7: Monitoring requirements relevant to contamination management.....	24

Annexures

Annexure A Conditions of Approval and Revised Environmental Mitigation Measures relevant to this Plan	26
Annexure B Unexpected Contaminated Land and Asbestos Finds Procedure	29

Glossary / Abbreviations

Abbreviations	Expanded text
ACM	Asbestos containing material
AMP	Asbestos Management Plan (JHCPB Asbestos Management Procedure and supporting integrated safety management system documents)
BTEXN	Benzene, toluene, ethyl benzene, xylenes and naphthalene
CEMP	Construction Environmental Management Plan
CLM Act	<i>Contaminated Land Management Act 1997</i>
CLMP	Contaminated Land Management Plan (this document)
CoA	Conditions of Approval
Contamination Paper, the	Technical working paper: Contamination (AECOM, 2017)
DPE	Department of Planning and Environment
DPI	Department of Primary Industries
EIS, the	WestConnex M4-M5 Link Environmental Impact Statement
EEC	Endangered Ecological Community
EPA	NSW Environment Protection Authority
ESA	Environmental Site Assessment
EWMS	Environmental Work Method Statements
IS	Infrastructure Sustainability
JHCPB	John Holland CPB Contractors Joint Venture
LNAPL	Light Non-Aqueous Phase Liquid
LTEMP	Long Term Environment Management Plan
OCPs	Organochlorine pesticides
OEH	Office of Environment and Heritage
PAHs	Polycyclic aromatic hydrocarbons
PESCP	Progressive Erosion and Sediment Control Plan
PFAS	Per- and poly-fluoroalkyl substances
PFOS	Perfluorooctyl sulfonate
PFHxS	Perfluorohexane sulfonic acid
Project, the	Rozelle Interchange and Western Harbour Tunnel Enabling Works Project
RAP	Remediation Action Plan
REMMs, the	Revised Environmental Management Measures, as outlined in the SPIR
Roads and Maritime	Roads and Maritime Services
SAR	Site Audit Report
SAS	Site Audit Statement
SPIR, the	WestConnex M4-M5 Link Submissions and Preferred Infrastructure Report
SVOCs	Semivolatile organic compounds
SSWMP	Soil and Surface Water Management Plan
TRH	Total Recoverable Hydrocarbons
VENM	Virgin Excavated Natural Material
VOCs	Volatile organic compounds
WHS Management Plan	Construction Workplace Health and Safety Management Plan
WMP	Waste Management Plan

1. Introduction

This Contaminated Land Management Sub Plan (CLMP) forms part of the Construction Environmental Management Plan (CEMP) for the Design and Construction of Rozelle Interchange and Western Harbour Tunnel Enabling Works Project (the Project). This CLMP outlines how John Holland CPB Contractors (JHCPB) Joint Venture will manage contaminated land during construction of the Project.

This CLMP has been prepared to address the requirements of the Minister’s Conditions of Approval (CoA), the revised environmental management measures (REMMs) listed in the WestConnex M4-M5 Link Submissions and Preferred Infrastructure Report (SPIR) and all applicable legislation. This CLMP will be updated following completion of the Site Contamination Reports required by Condition E181 (including Phase 2 Environmental Site Assessment (ESA)) and receipt of the Environment Protection Licence (EPL).

The Project description and key construction sites are outlined in Section 1.3 of the CEMP. Section 1.5 of the CEMP includes an overview of the Project environmental management system.

2. Purpose and objectives

2.1. Purpose

The purpose of this CLMP is to establish a set of best practice procedures for the identification and management of contaminated land if encountered during works undertaken for the Project.

This plan has been prepared to address the applicable statutory requirements and aims to ensure that the commitments with regard to contaminated land are met.

2.2. Objectives

The key objective of the CLMP is to ensure all CoA, REMMs and licence/permit requirements relevant to contaminated land are described, scheduled and assigned responsibility as outlined in:

- The WestConnex M4-M5 Link Environmental Impact Statement (the EIS),
- The SPIR prepared for WestConnex M4-M5 Link,
- The Modification Report and Response to Submissions Report prepared for the Mainline Tunnel Modification,
- The Conditions of Approval granted to the project on 17 April 2018 and modified on 25 February 2019,
- Roads and Maritime specifications G36, G38 and G40,
- The Project’s Environment Protection Licence (EPL), and
- Other additional approvals, authorisations, licences relevant to contaminated land.

2.3. Environmental Performance Outcomes and Targets

The desired environmental performance outcome for contaminated land, as outlined and addressed in the EIS, is that:

- Risks arising from the disturbance and excavation of land and disposal of soil are minimised, including disturbance to acid sulfate soils and site contamination.

To achieve this outcome, JHCPB will undertake the Project outcomes and targets in Table 1.

Table 1: Performance outcomes

No.	Performance Outcome	Source	Document Reference
1	Manage acid sulfate soils in accordance with good practice measures	EIS, Appendix A	Section 6.2
2	Manage contamination to protect environmental values and human health.	EIS, Appendix A	Section 6.2

No.	Performance Outcome	Source	Document Reference
3	Full compliance with the relevant legislative requirements, CoA, REMMs and Roads and Maritime specifications.	Best Practice	Section 3
4	Manage downstream water quality impacts attributable to the project (i.e. maintain groundwater and surface waterway health by avoiding the introduction of nutrients, sediment and chemicals outside of that permitted by the environmental protection licence and/or ANZECC guidelines).	Best Practice	Section 6.3
5	Ensure training on best practice soil and water management is provided to all construction personnel through site inductions.	Best Practice	Section 7.2

3. Environmental Requirements

3.1. Relevant legislation and guidelines

3.1.1. Legislation

All legislation relevant to this CLMP is included in Annexure A1 Legal Requirements and Compliance Tracking of the CEMP.

3.1.2. Guidelines and standards

The main guidelines, specifications and policy documents relevant to this Plan include:

- National Environmental Protection (Assessment of Site Contamination) Amendment Measure 1999 revised 2013 (No. 1) (2013),
- Waste Classification Guidelines – Part 1: Classification of waste (NSW EPA 2014),
- Roads and Maritime QA Specification G36 – Environmental Protection,
- Roads and Maritime Guideline for the Management of Contamination, September 2013
- Environmental Procedure Management of Wastes on Roads and Maritime Services Land (Roads and Maritime 2014),
- Roads & Maritime Services Environmental Incident Classification and Reporting Procedure (2017),
- NSW Environment Protection Authority (EPA) Contaminated Land Management – Guidelines for the NSW Site Auditor Scheme (3rd edition) (2017),
- NSW Department of Planning State Environmental Planning Policy 55 – Remediation of Land,
- Department of Urban Affairs and Planning and Environment Protection Authority Planning Guidelines SEPP 55 – Remediation of Land (1998),
- NSW Office of Environment and Heritage (2011) Guidelines for Consultants Reporting on Contamination Sites,
- Guidelines on the Duty to Report Contamination under the Contaminated Land Management Act 1997 OEH (2009),
- Acid Sulfate Soils Manual (Acid Sulfate Soil Management Advisory Committee 1998),
- Approved Methods for Sampling and Analysis of Water Pollutants in NSW (EPA 2004),
- Australian/New Zealand Standard 5667.1:1998 Water Quality – Sampling – Part 1: Guidance on the Design of Sampling Programs, Sampling Techniques and the Preservation and Handling of Samples (Standards Australia 1998),
- Australian/New Zealand Standard 5667.11:1998. Water Quality - Sampling - Guidance on Sampling of Groundwaters,
- Australian and New Zealand Guidelines for Fresh and Marine Water Quality (ANZECC 2000),

- Code of Practice How to Manage and Control Asbestos in the Workplace (SafeWork NSW 2016),
- Code of Practice How to Safely Remove Asbestos (SafeWork NSW 2016),
- Guidelines for the Assessment and Management of Groundwater Contamination (Department of Environment and Conservation (DEC 2007), and
- WestConnex Sustainability Strategy (WestConnex Delivery Authority 2015).

4. Existing Environment

This section describes the existing environment of the Project, specific to contaminated land. It also summarises previous contaminated land investigations undertaken to date and outlines further investigation required.

4.1. Previous investigations

A Technical working paper: Contamination (AECOM, 2017) (the Contamination Paper) was completed to inform the M4-M5 Link EIS. Sites which were assessed within the Contamination Paper as potentially containing soil or groundwater contamination that could pose an unacceptable risk to human or ecological receptors during construction of the Project require further intrusive site investigation. Table 2 summarises the potential contaminants of concern identified in the Contamination Paper associated with the sites relevant to this CLMP.

Table 2: Potential contaminants of concern

Site	Potential contamination source	Contaminants of concern
Rozelle civil and tunnel site (C5)	<ul style="list-style-type: none"> ▪ Fill on site contains elevated concentrations of contaminants above applicable human health and ecological criteria. Asbestos was also identified in fill in several locations ▪ Previous uses as a timber yard, rail yard and for manufacturing ▪ Acid sulfate soil risk identified ▪ 	<ul style="list-style-type: none"> ▪ Metals ▪ Total Recoverable Hydrocarbons (TRH) ▪ Polycyclic aromatic hydrocarbons (PAHs) ▪ Asbestos ▪ Acid sulfate soils ▪ Organochlorine pesticides (OCPs) ▪ Lead ▪ Light Non-Aqueous Phase Liquids (LNAPL)
The Crescent civil site (C6)	<ul style="list-style-type: none"> ▪ Imported fill of unknown origin ▪ Elevated concentrations of contaminants above ecological criteria ▪ Acid sulfate soil risk identified ▪ Potential for up-gradient contaminants to be mobilised via sediment and stormwater flowing into Whites Creek and Easton Park drain into Rozelle Bay. ▪ Previous uses of the Rozelle civil and tunnel site (C5) nearby ▪ Boat maintenance activities within Rozelle Bay. 	<ul style="list-style-type: none"> ▪ Asbestos ▪ Per- and poly-fluoroalkyl substances (PFAS) – perfluorooctyl sulfonate (PFOS) and perfluorohexane sulfonic acid (PFHxS) ▪ Metals ▪ PAHs ▪ Phthalates ▪ Acid sulfate soils ▪ Tributyltin ▪ Semi-volatile organic compounds (SVOCs) ▪ Volatile organic compounds (VOCs) ▪ TRH ▪ Benzene, toluene, ethylbenzene, xylenes and naphthalene (BTEXN)
Victoria Road civil site (C7)	<ul style="list-style-type: none"> ▪ Previous underground petroleum storage system located on site, which has a risk of historical leaks ▪ Demolition of former buildings (potentially containing asbestos or lead paint). 	<ul style="list-style-type: none"> ▪ TRH ▪ BTEXN ▪ PAHs ▪ Lead ▪ Asbestos
Iron Cove Link civil site (C8)	<ul style="list-style-type: none"> ▪ Demolition of former buildings (potentially containing asbestos or lead paint) ▪ Imported fill from an unknown origin ▪ Previous mechanical workshops and petrol station on the site may have stored and handled oils, fuels and solvents and the former underground petroleum storage system including has a risk of historical leaks ▪ Acid sulfate soil risk identified. 	<ul style="list-style-type: none"> ▪ Metals ▪ TRH ▪ BTEX ▪ PAHs ▪ OCPs ▪ PCBs ▪ Asbestos ▪ VOCs ▪ SVOCs

All Project construction sites are described in Section 1.3.2 of the CEMP.

4.2. Further investigations

Analysis of information from further investigations currently being undertaken at targeted locations will refine the level of confidence in data regarding site characterisation and waste classification. Additional investigation of specific site will be undertaken as required prior to and during construction to ensure appropriate identification of contamination, assessment for reuse, waste classification and, where required, appropriate remediation and validation.

5. Environmental aspects and impacts

5.1. Construction activities

Key aspects of the Project that could result in adverse impacts to contamination include:

- Pre-construction activities including utility adjustment, site access provisions, property adjustments,
- Clearing of vegetation,
- Initial removal of topsoil,
- General earthworks particularly during site establishment,
- Building demolition,
- Removal of redundant utilities,
- Construction of site compounds and spoil / mulch and / or equipment stockpile areas,
- Temporary access roads during construction,
- Bulk Earthworks, and
- Drilling and Blasting.

Refer to Annexure A2 of the CEMP – Environmental Aspects and impacts register.

5.2. Impacts

The potential for contaminated land disturbance and impacts will depend on a number of factors. Primarily impacts will be dependent on the nature, extent and magnitude of construction activities and their interaction with known and potential contaminated land sources. If present and not appropriately controlled, there is potential for contamination to impact soil and water during construction. Potential impacts attributable to construction activities might include:

- Demolition activities to mobilise contaminants (asbestos containing material (ACM) and lead paint),
- Inhalation, exposure and/or ingestion risk to site workers and surrounding land users from hazardous building materials and PAHs in excavated soil via dust,
- Cross contamination associated with the incorrect handling or disposal of spoil/unexpected finds,
- Direct contact, inhalation and ingestion risk to site workers from contaminated soil or hazardous building materials via dust,
- Discharge of contaminated surface water to the stormwater systems,
- Direct contact, inhalation and ingestion risk to site workers or surrounding human receptors from dust generated from contaminated soil ,
- Disturbance of actual or potential ASS which could impact local soil and water quality,
- Accidental leaks and spills from the use of the site as a construction ancillary site, and
- Potential for leaks or spills from equipment and plant used during construction.

Relevant aspects and the potential for related impacts have been considered in a risk assessment at Annexure A2 of the CEMP. Section 6 provides a suite of mitigation measures that will be implemented to avoid or minimise those impacts.

As stated in Chapter 26 (Cumulative Impacts) of the EIS the construction of the Project is not anticipated to create additional soil or groundwater contamination to that already identified within the Project footprint as a result of historical land use activities. It is likely that construction activities would result in an overall improvement in the condition of the land at Project completion with appropriate management of contaminated materials.

The risk assessment as stated in Chapter 16 (Contamination) of the EIS for the aforementioned impacts for surface works during construction is presented below in Table 3.

Table 3: Risk assessment for potential construction impacts

Site	Construction works	Known or Potential Site Contamination	Likelihood of Contamination	Likelihood of Exposure	Risk
Rozelle civil and tunnel site (C5)	<ul style="list-style-type: none"> ▪ Excavations for tunnel portals and cut and cover tunnels ▪ Road construction ▪ Stockpiling in acoustic sheds ▪ Construction of temporary and permanent infrastructure ▪ Tunnelling (for ventilation/road construction) ▪ Utility works ▪ Drainage infrastructure including upgraded culvert to Rozelle Bay 	<p>Previous soil investigations identified metals (lead, arsenic, cadmium and zinc), asbestos, petroleum sourced Light Non-Aqueous Phase Liquid (LNAPL) and PAHs at concentrations that exceeded the land use criteria for open space and commercial/industrial. Potential construction impacts include:</p> <ul style="list-style-type: none"> ▪ Impacts on site workers and the local community through contact with contaminants and asbestos released during demolition and ground disturbance works ▪ Exposure of underlying ground surface following removal of vegetation, ballast stockpile and excavated spoil resulting in the potential mobilisation of contamination that may be present within the site ▪ Migration of LNAPL beyond current plume contaminating a greater area of soil and groundwater ▪ Contamination resulting from potential leaks and spills from equipment and plant ▪ Cross contamination from the incorrect handling of contaminated soil, fill, sediment, groundwater and surface water ▪ Erosion and offsite transport of sediment and contamination via overland flow and stormwater runoff, affecting the water quality of Easton Park drain, Whites Creek and Rozelle Bay ▪ Direct contact, inhalation and ingestion risk to site workers from contaminated soil or hazardous building materials via dust ▪ Discharge of contaminated surface water and extracted groundwater to the stormwater system and ultimately Rozelle Bay ▪ Disturbance of actual or potential acid sulfate soils at the western end of the site which could impact local soil and water quality. ▪ Adverse impacts on ecological receptors from the discharge of contaminated surface water and sediment to Rozelle Bay 	Known to be present and widespread	Exposure pathway likely to be present	High
The Crescent civil site (C6)	<ul style="list-style-type: none"> ▪ Utility works ▪ Temporary stockpiling ▪ Road works, including construction of a new road bridge over Whites Creek ▪ Widening and improvement works along Whites Creek 	<p>Previous investigations have indicated soil, sediment and groundwater contamination associated with historical filling and more recent industrial/commercial maritime operation. There is an existing management plan to manage identified contamination on part of the site. Potential construction impacts include:</p> <ul style="list-style-type: none"> ▪ Impacts on site workers and the local community through contact with contaminants and asbestos released during demolition and ground disturbance works 	Known to be present and widespread	Exposure pathway likely to be present	High

Site	Construction works	Known or Potential Site Contamination	Likelihood of Contamination	Likelihood of Exposure	Risk
	<ul style="list-style-type: none"> ▪ Construction of the culvert below City West Link (Easton Park drain) ▪ Construction and dewatering of coffer dam(s) in Rozelle Bay ▪ Finishing works ▪ Excavating, filling and grading of disturbed areas ▪ Landscaping and construction of pedestrian and cyclist paths and bridges. 	<ul style="list-style-type: none"> ▪ Exposure of underlying ground surface during excavation resulting in the potential mobilisation of contamination ▪ Contamination resulting from potential leaks and spills from equipment and plant ▪ Erosion and offsite transport of sediment and contamination via overland flow and stormwater runoff, affecting the water quality of Whites Creek and Rozelle Bay ▪ Adverse impacts on the environment as a result of the inappropriate management of waste generated by construction activities ▪ Direct contact, inhalation and ingestion risk to site workers from contaminated soil or hazardous building materials via dust ▪ Adverse impacts on ecological receptors from the discharge of contaminated surface water and sediment to Rozelle Bay ▪ Adverse impacts on ecological receptors from the mobilisation of disturbed contaminated sediment within Rozelle Bay ▪ Cross contamination from the incorrect handling of contaminated soil, fill, sediment, groundwater and surface water ▪ Accidental spills and leaks from equipment and plant used during construction ▪ Disturbance of actual or potential acid sulfate soils at the western end of the site which could impact local soil and water quality. 			
Victoria Road civil site (C7)	<ul style="list-style-type: none"> ▪ Demolition of existing buildings 	<p>There are historical land uses within and surrounding the site which may have caused soil and potentially groundwater contamination. Further investigations would be required to assess the risk posed during construction.</p> <p>There is potential for inhalation and ingestion risk to site workers from contaminated soil or hazardous building materials via dust, and the potential for leaks or spills from equipment and plant used during construction.</p>	Very unlikely and limited in extent	Exposure pathway likely to be present	Low

Site	Construction works	Known or Potential Site Contamination	Likelihood of Contamination	Likelihood of Exposure	Risk
Iron Cove Link civil site (C8)	<ul style="list-style-type: none"> ▪ Bulk excavations for tunnel portals and cut-and-cover tunnels ▪ Soft ground tunnelling ▪ Road construction works ▪ Construction of permanent operational infrastructure ▪ Installation of the Humegard and Humeceptor ▪ Utility works ▪ Landscaping. 	<p>There are historical land uses within and surrounding the site which may have caused soil and potentially groundwater contamination. Further intrusive investigations would be required to assess the risk posed during construction of areas of potential concern.</p> <p>Potential construction impacts include:</p> <ul style="list-style-type: none"> ▪ Direct contact, inhalation and ingestion risk to site workers from contaminated soil or hazardous building materials via dust ▪ Discharge of contaminated surface water to the stormwater system and ultimately Iron Cove ▪ Disturbance of actual or potential acid sulfate soils at the northeast corner of the site and within the area of the proposed gross pollutant trap located within King George Park, adjacent to Manning Street at Rozelle ▪ Potential for leaks or spills from equipment and plant used during construction. 	Potentially present and widespread	Exposure pathway likely to be present	Medium

Section 6 provides a suite of mitigation measures that will be implemented to avoid or minimise potential impacts identified in Table 3.

6. Environmental control measures

6.1. Contamination Management Process

The contamination assessment process for the Project and provision of recommendations for subsequent remediation and/or management will be completed with reference to relevant State and National guidance documents, endorsed under section 105 of the CLM Act including:

- Guidelines for the NSW Auditor Scheme (3rd Edition), Department of Environment and Conservation NSW (DEC 2017),
- Guidelines for Consultants Reporting on Contaminated Sites, Office of Environment and Heritage (OEH 2011),
- National Environment Protection (Assessment of Site Contamination) Measure (NEPM) 1999, National Environment Protection Council (NEPC 2013), and
- Contaminated Sites: Sampling Design Guidelines (NSW EPA 1995).

Specific measures and requirements to meet the objectives of this CLMP by addressing contract specifications, CoA and REMMs in relation to impacts on contaminated land are outlined in Table 4 and Table 5.

6.1.1. Phase 1 Environmental Site Assessment

Site-specific Phase 1 Environmental Site Assessments (ESA) are undertaken to determine whether potential site contamination poses an actual or potential risk to human health and the environment, either on or off the site. The ESA is also undertaken to determine if additional intrusive investigations are required. A thorough understanding of the contaminants of concern are ascertained, including whether potentially contaminated soil is in an area of cut / fill or is likely to be unsuitable for construction purposes.

Outcomes of site-specific Phase 1 ESAs will be prepared and the outcomes will be presented to the Project appointed NSW EPA accredited Site Auditor for review if an RAP is required. Where no further action is proposed advice by the Site Auditor will be sought prior to confirming not to progress to Phase II or other further investigations.

6.1.2. Phase 2 Sampling, Analytical and Quality Plan

Where soil sampling investigations are deemed necessary, a Phase 2 Sampling Analysis and Quality Plan (SAQP) will be prepared to assess the nature and extent of potential contamination. A SAQP will be developed to inform the Phase 2 ESA in accordance with the EPA (1995) Sampling Design Guidelines or activity specific guidelines.

6.1.3. Phase 2 Environmental Site Assessment

A Phase 2 ESA will be undertaken where the Phase 1 ESA concludes a Phase 2 investigation is required. This Phase 2 ESA will meet the requirements of the Soil Contamination Report required by CoA E181 and E182. Where a Phase 2 ESA is required the assessment process outlined in the NEPM will be followed when determining whether sites within the Project footprint are contaminated.

A Phase 2 ESA report will be prepared which includes:

- Identification of the type, extent and concentration of contaminants of concern,
- Information on the potential effects of contaminants on public health and the environment,
- Off-site impacts on soil, sediment and biota (where applicable),
- The adequacy and completeness of all information available to be used in making decisions on remediation or site management,
- An assessment of whether the EPA should be notified under Section 60 of the CLM Act,

- Identification of preferred options for remediation and/or site management (i.e. whether the contamination is in an area of cut or fill; preferentially either to be retained in situ, reused within the Project boundary, or disposed offsite), and
- If removal of the contaminated material from site is a remediation option, analysis of the material and classification under the Waste Classification Guidelines Part 1: Classifying waste (NSW EPA, 2014) and specification that the movement of all potentially contaminated material will be tracked and recorded as per the Waste Management Sub- plan. Waste classification will be an action of the Phase 2 EAS but not form part of it.

The Phase 1 and Phase 2 contamination assessments will be prepared by a suitably qualified and experienced person in accordance with guidelines made or approved under the Contaminated Land Management Act 1997 (NSW).

If the Phase 2 ESA prepared under the CoA E181 identifies contamination, a site audit is required to determine the suitability of a site for the operational use of the Project. If a site audit is required, a Site Audit Statement and Site Audit Report must be prepared by a NSW EPA Accredited Site Auditor.

Contaminated land must not be used for the operational purpose identified in the EIS or SPIR until a Site Audit Statement is obtained that declares the land is suitable for that purpose and any conditions on the Site Audit Statement have been complied with.

The Phase 2 ESA will be reviewed by the Site Auditor.

The Phase 2 ESA may include a recommendation for the development of a Remediation Action Plan (RAP), dependent on the operational land use. Where a RAP is not deemed necessary, the Phase 2 ESA will contain a table in plain English that details all steps, controls and data that must be collected or implemented.

6.1.4. Remediation Action Plan

A RAP will be developed, where required by the Site Contamination Report to establish the remediation objectives and detail the strategy for sites identified as requiring remediation to make them suitable for the land use identified in the EIS or SPIR. The RAP will demonstrate how the risks of contamination will be reduced to within acceptable levels. Where required, RAPs for the Project will:

- Set remediation goals that ensure the remediated site will be suitable for the land use and will pose no unacceptable risk to human health or to the environment
- Document requirements to be implemented to reduce risks to workers during remediation
- Outline sampling requirements to validate that the remediation strategy has been successful.

RAPs will contain a table in plain English that details all steps, controls and data that must be collected or implemented to implement the RAP. RAPs will be prepared and submitted to the Site Auditor to seek interim advice.

6.1.5. Remediation Validation Report

Where a RAP has been implemented, a Remediation Validation Report (RVR) is required to confirm that the remediation goals specified under the RAP have been achieved. The report will detail:

- Descriptions of remedial action undertaken
- The validation results of the remediation action undertaken on the site
- Confirmation that all regulatory requirements, where applicable, have been met
- Identification of any residual contamination with discussion of any associated risks and an outline of control measures required.

RVRs will be submitted to the Site Auditor to inform site audit statements. Where residual contamination is retained onsite, the RVR may be accompanied by a Long Term Environmental Management Plan (LTEMP).

6.1.6. Long Term Environmental Management Plan

A LTEMP may be required to ensure:

- The environment is protected,
- Site users are not exposed to contamination,
- The site is suitable for its intended land use where:
 - › Complete clean-up of contamination affecting a site is not practicable,
 - › Contaminants are being capped or contained on-site, and
 - › Remediation is likely to cause a greater adverse impact than would occur if the site were left undisturbed.

An LTEMP would ensure activities which could potentially result in exposure of future land users to the residual contaminated soils and/or groundwater beneath the site, are precluded or appropriately limited/controlled.

Where required, an LTEMP will be prepared to succinctly describe the nature and location of contamination at a site. It will state what the objectives of the plan are, how contaminants are to be managed, who would be responsible for the plan's implementation and over what timeframe actions specified in the plan would take place.

In addition, an LTEMP will document the following:

- Administrative controls,
- Program of inspections and maintenance,
- Protocols on intrusive site works,
- Protocols for on-site use and limitations,
- List roles and responsibilities,
- Contact details, and
- Emergency and Incident Response Plan.

The LTEMP will be reviewed by the Site Auditor consistent with the Auditor Guidelines (DEC NSW, 2017).

6.1.7. Site Audit Report and Site Audit Statements

A site audit will be completed in accordance with CoA E182 if contamination is identified the Site Contamination Report. A Site Audit Statement(s) (SAS) and Site Audit Report (SAR) will be prepared as part of the site audit. The report and statement will detail the determination of suitability of the site for its intended future specified use. The site audit, SAS and SAR preparation will be undertaken by a NSW EPA accredited Site Auditor.

A copy of the Site Audit Statement and Site Audit Report will be submitted to the Secretary and relevant council for information no later than one month prior to the commencement of operation.

6.2. Management strategies

Contamination management strategies are to be implemented prior to and throughout the construction phase. Management strategies for ancillary facilities and Project footprint are detailed in Table 4. These strategies are derived from the REMMs. Phase 2 reports for all moderate and high risk sites will detail strategies based on additional investigative work and data collection.

Table 4: Project controls for contamination management

Site	Overall contamination risk	Investigations	Recommended remediation strategy	Validation Reporting
Rozelle civil and tunnel site (C5)	High	<p>Hazardous materials assessment and management plans are to be undertaken for buildings and structures prior to demolition.</p> <p>Investigations to date have identified existing localised contamination from asbestos, PAHs, hydrocarbons and metals, and a site wide presence of acid sulfate soils.</p> <p>Additional Phase 2 ESA to be completed prior to commencement of construction targeting existing data gaps.</p> <p>Review all existing contamination data to manage risk and mitigation measures for construction workers.</p>	<p>RAP to be developed for the site where required by the Site Contamination Report.</p> <p>Implement control measures protective of construction workers as necessary.</p>	<p>A Validation Report is required following implementation of the site-specific RAP.</p> <p>Validation of remediation works is required to confirm site suitability. Report to also include waste tracking and disposal.</p>
The Crescent civil site (C6)	High	<p>Existing investigations have identified localised contamination from asbestos, PAHs and metals including tributyl tin and a site wide presence of acid sulfate soils.</p> <p>Additional Phase 2 ESA to be completed prior to commencement of construction targeting existing data gaps.</p> <p>Review all existing contamination data to manage risk and mitigation measures for construction workers.</p>	<p>RAP to be developed for the site where required by the Site Contamination Report.</p> <p>Implement control measures protective of construction workers as necessary.</p>	<p>A Validation Report is required following implementation of the site-specific RAP.</p> <p>Validation of remediation works is required to confirm site suitability. Report to also include waste tracking and disposal.</p>
Victoria Road civil site (C7)	Low	<p>Hazardous materials assessment and management plans are to be undertaken for buildings and structures prior to demolition.</p> <p>Review all existing contamination data to manage risk and mitigation measures for construction workers.</p>	<p>RAP to be developed for the site where required by the Site Contamination Report.</p> <p>Implement control measures protective of construction workers as necessary.</p>	<p>RAP to be developed for the site where required by the Site Contamination Report.</p> <p>Implement control measures protective of construction workers as necessary.</p>

Site	Overall contamination risk	Investigations	Recommended remediation strategy	Validation Reporting
Iron Cove Link civil site (C8)	Medium	<p>Hazardous materials assessment and management plans are to be undertaken for buildings and structures prior to demolition.</p> <p>No previous data available to date. A Phase 2 contamination investigation is in the process of being undertaken.</p> <p>Phase 2 ESA to be completed prior to commencement of construction targeting existing data gaps.</p> <p>Review all existing contamination data to manage risk and mitigation measures for construction workers.</p>	<p>RAP to be developed for the site where required by the Site Contamination Report.</p> <p>Implement control measures protective of construction workers as necessary.</p>	<p>A Validation Report is required following implementation of the site-specific RAP.</p> <p>Validation of remediation works is required to confirm site suitability. Report to also include waste tracking and disposal.</p>

6.3. General environmental safeguards

Environmental safeguards to manage contaminated land and minimise the creation of additional contaminated land and water that are not captured by other management plans or procedures are identified in Table 5. Elimination of the hazard is the first preference of control, followed by engineering, then administrative controls. These controls include the legal and Project requirements identified in the CoA, the EIS, the SPIR, RMS specifications, and standard practice measures.

Table 5: Contaminated land management and mitigation measures

ID	Measure/requirement	Resources needed	When to implement	Responsibility	Reference	Evidence
Investigation						
CL1	<p>A Site Contamination Report, documenting the outcomes of Phase 1 and Phase 2 contamination assessments of land upon which the CSSI is to be carried out, that is suspected, or known to be, contaminated must be prepared by a suitably qualified and experienced person in accordance with guidelines made or approved under the Contaminated Land Management Act 1997 (NSW).</p> <p>Targeted site investigations are to be undertaken to investigate identified areas of concern within the following sites:</p> <ul style="list-style-type: none"> Rozelle civil and tunnel site at Rozelle (C5) The Crescent civil site at Annandale (C6) Iron Cove Link civil site at Rozelle (C8). 	Suitably qualified Contamination Consultants	Pre-construction	Environment and Sustainability Manager	CoA E181, REMM CM01	Phase 2 ESA and RAP

ID	Measure/requirement	Resources needed	When to implement	Responsibility	Reference	Evidence
CL2	If a Site Contamination Report prepared under Condition E181 finds such land contains contamination, a site audit is required to determine the suitability of a site for a specified use. If a site audit is required, a Site Audit Statement and Site Audit Report must be prepared by a NSW EPA Accredited Site Auditor. Contaminated land must not be used for the purpose approved under the terms of this approval until a Site Audit Statement is obtained that declares the land is suitable for that purpose and any conditions on the Site Audit Statement have been complied with.	EPA accredited Site Auditor	Pre-operation	Environment and Sustainability Manager	CoA E182	Site Audit Statement and Site Audit Report
CL3	A copy of the Site Audit Statement and Site Audit Report must be submitted to the Secretary and relevant council for information no later than one (1) month prior to the commencement of operation.	Environment Manager	Pre-operation	Environment and Sustainability Manager	CoA E183	Evidence of transmittal or receipt
CL4	A hazardous materials assessment will be carried out prior to and if required during the demolition of buildings. Demolition works will be undertaken in accordance with the relevant Australian Standards and relevant NSW WorkCover Codes of Practice, including the Work Health and Safety Regulation 2011 (NSW).	WHS Management Plan	Prior to and during demolition	Environment and Sustainability Manager/ WHS Officer	REMM CM03	Compliance tracking
Management of contaminated soils and materials						
CL5	Wastes will be managed and disposed of in accordance with relevant NSW legislation and government policies.	WMP	Prior to and during demolition and construction	Environment and Sustainability Manager	REMM RW2	Compliance tracking and waste records
CL6	A Construction Waste Management Plan will be prepared as part of the CEMP and regularly updated during detailed design and construction, detailing appropriate procedures for waste management. The plan will include the waste management measures described in this EIS.	Environmental Advisor	Prior to and during demolition and construction	Environment and Sustainability Manager	REMMs RW3 & CM04	WMP

ID	Measure/requirement	Resources needed	When to implement	Responsibility	Reference	Evidence
CL7	<p>Wastes will be managed using the waste hierarchy principles of:</p> <ul style="list-style-type: none"> ▪ Avoidance of unnecessary resource consumption to reduce the quantity of waste being generated ▪ Recovery of resources for reuse onsite or offsite for the same or similar use, without reprocessing ▪ Recovery of resources through recycling and reprocessing so that waste can be processed into a similar non-waste product and reused ▪ Disposal of residual waste. 	WMP	Prior to and during demolition and construction	Environment and Sustainability Manager	REMM RW4	Compliance tracking
CL8	<p>Resource recovery will be applied to the management of construction waste and will include:</p> <ul style="list-style-type: none"> ▪ Recovery of resources for reuse – reusable materials generated by the Project will be segregated for reuse onsite, or offsite where possible, including the reuse of the major waste streams (VENM) ▪ Recovery of resources for recycling – recyclable resources (such as metals, plastics and other recyclable materials) generated during construction and demolition ▪ Resources will be segregated for recycling and sent to an appropriate recycling facility for processing ▪ Recovery of resources for reprocessing – cleared vegetation will be mulched or chipped. 	WMP	Prior to and during demolition and construction	Environment and Sustainability Manager	REMM RW5	Compliance tracking
CL9	Options identified for the off-site reuse of waste will comply with relevant NSW EPA resource recovery exemptions and requirements.	WMP	Prior to and during demolition and construction	Environment and Sustainability Manager	REMM RW6	Compliance tracking
CL10	<p>The Construction Waste Management Plan will document anticipated volumes of spoil that will be generated by the project, spoil storage locations within Project sites and likely spoil disposal sites.</p> <p>The Construction Waste Management Plan and spoil reuse opportunities will be regularly reviewed and updated during detailed design and Project construction.</p>	WMP	Prior to and during construction	Environment and Sustainability Manager	REMM RW7	Compliance tracking

ID	Measure/requirement	Resources needed	When to implement	Responsibility	Reference	Evidence
CL11	The project will reuse or recycle around 95 per cent of uncontaminated spoil generated for beneficial purposes, either within the Project or at other locations in accordance with the Project spoil management hierarchy.	WMP	Prior to and during construction	Environment and Sustainability Manager	REMM RW8	Compliance tracking
CL12	A Construction Soil and Water Management Plan for the project includes procedures to minimise the interaction of stormwater with contaminated land, including acid sulfate soils, and manage potentially contaminated stormwater runoff, as described in Chapter 15 (Soil and water quality) of the EIS.	SSWMP	Prior to and during construction	Environment and Sustainability Manager	REMM CM07	Approved SSWMP
CL13	Measures identified in Chapter 25 (Hazard and risk) of the EIS will be implemented to appropriately store contaminated materials and materials with the potential to cause contamination and reduce the potential for environmental contamination due to spills and leaks.	WHS Management Plan	Prior to and during demolition	Environment and Sustainability Manager / WHS Officer	REMM CM08	Site inspections
CL14	Stockpile management procedures will be implemented to control dust, odour, cross contamination and erosion and sedimentation.	SWMP	Prior to and during construction	Environment and Sustainability Manager	REMMs CM05, RW11	Site inspections
CL15	All contaminated waste material will be stockpiled separately from other waste material including a suitable gap between stockpiles to minimise the risk of cross contamination of stockpiles.	SWMP	During construction	Environment and Sustainability Manager	Best Practice	Site inspections
Unexpected finds management						
CL15	An Unexpected Contaminated Land and Asbestos Finds Procedure must be prepared as outlined in the Guideline for the Management of Contamination (RMS 2013), and must be followed should unexpected contaminated land or asbestos be excavated or otherwise discovered during construction. The procedure will include: <ul style="list-style-type: none"> ▪ Cease work in the vicinity ▪ Initial assessment by an appropriately qualified environmental consultant ▪ Further assessment and management of contamination, if confirmed, in accordance with section 105 of the CLM Act. 	Suitably qualified Contamination Consultant	During construction	Environment and Sustainability Manager / WHS Officer	CoA E184, REMMs CM06 & RW10	Annexure B form

ID	Measure/requirement	Resources needed	When to implement	Responsibility	Reference	Evidence
CL16	The Unexpected Contaminated Land and Asbestos Finds Procedure must be implemented throughout construction.	Appendix 2: Unexpected Contaminated Land and Asbestos Finds Procedure	During construction	Environment and Sustainability Manager / WHS Officer	CoA E185	Compliance tracking
CL17	Suitable areas will be identified to allow or contingency management of unexpected waste materials, including contaminated materials. Suitable areas will be hardstand or lined areas that are appropriately stabilised and banded, with sufficient area for stockpile storage.	Environment Manager and Site Supervisor	During construction	Environment and Sustainability Manager / WHS Officer	REMM RW9	Inspection reports
Asbestos Management						
CL18	An asbestos survey is to be undertaken by a suitably qualified person, of buildings to be demolished as part of the Project in accordance with the Asbestos Management Plan.	Suitably qualified Consultant and Asbestos Management Plan (AMP)	Prior to demolition	Environment and Sustainability Manager / WHS Officer	REMM RW13	HazMat reports
CL19	All asbestos or other hazardous building materials identified in buildings will be removed prior to demolition works commencing.	Licensed removal specialist	Prior to and during demolition	Environment and Sustainability Manager / WHS Officer	Asbestos removal guidelines	Inspection and clearance reports
CL20	Asbestos handling and management will be undertaken in accordance with an Asbestos Management Plan (or similar) prepared in accordance with relevant legislation, regulations and codes of practice) as described in Chapter 23 (Resource use and waste minimisation) of the EIS.	WHS Officer, Site Supervisor and AMP (JHCPB Asbestos Management Procedure and supporting integrated safety management system documents)	Prior to and during demolition, site clearance and excavation in fill / utilities.	Environment and Sustainability Manager / WHS Officer	REMM CM02 & RW14	Inspection reports

7. Compliance management

7.1. Roles and responsibilities

JHCPB's organisational structure and overall roles and responsibilities are outlined in Section 3.3 of the CEMP. Specific responsibilities for the implementation of environmental controls are detailed in Section 6 of this Plan.

7.2. Training

All employees, contractors and utility staff working on site will undergo site induction training relating to contaminated land management issues. The induction training will address elements related to contaminated land management including:

- Project obligations including requirements to assess and classify contamination onsite,
- Recognising soil and groundwater contamination conditions and implementing the Unexpected Contaminated Land Finds Procedure (refer to Annexure B),
- Responsibilities pertaining to the management of contamination under the *Contaminated Land Management Act 1997* and the *Protection of the Environment Operations Act 1997*,
- Responsibilities under the Guidelines for the Assessment of On-site Containment of Contaminated Soil (ANZECC, 1999) and National Environmental Protection (Assessment of Site Contamination) Amendment Measure 1999 revised 2013 (No. 1) (NEPM, 2013),
- Responsibilities under the Guidelines for the Assessment and Management of Groundwater Contamination (NSW EPA 2007), and
- Responsibilities including tracking of waste under RMS Specification D&C G36.

Elements identified above may be delivered in targeted training relevant to personnel who may interact with the above issues rather than the induction.

Targeted training in the form of toolbox talks or specific training will also be provided to personnel with a key role in contaminated land management.

Further details regarding staff induction and training are outlined in Section 3.5 of the CEMP.

7.3. Monitoring and inspections

Reporting associated with construction at sites relevant to this CLMP is reproduced in Table 6.

Table 6: Reporting requirements relevant to contamination management

Item	Frequency	Standards	Reporting	Responsibility
Inspection				
Site inspections	Weekly	Waste Management Plan (WMP) This CLMP EPA Waste Classification Guidelines RMS Waste Fact Sheets: "Asbestos Waste" and "Waste Sampling"	Environmental Inspection Checklist	Environment and Sustainability Manager
Monitoring				
Material tracking	Daily	WMP EPA Waste Classification Guidelines	Waste Management Register	Spoil Manager

Additional requirements and responsibilities in relation to inspections are documented in Section 3.9.1 and Section 3.9.2 of the CEMP.

7.4. Auditing

Audits (both internal and external) will be undertaken to assess the effectiveness of environmental controls, compliance with this Plan, CoA and other relevant approvals, licenses and guidelines.

Audit requirements are detailed in Section 3.9.3 of the CEMP.

7.5. Reporting

Reporting associated with construction at sites relevant to this CLMP is reproduced in Table 7.

Table 7: Monitoring requirements relevant to contamination management

Item	Frequency	Standards	Responsibility
Waste Classification Reports	Prior to offsite spoil disposal	RAP EPA Waste Classification Guidelines	Spoil Manager
Validation Reports	Following remediation of a site	RAP National Environmental Protection (Assessment of Site Contamination) Amendment Measure 2013 (No. 1)	Environment and Sustainability Manager
Hazardous Materials Reports	Prior to demolition of buildings and structures	AMP Australian Standards and relevant NSW SafeWork Codes of Practice, and the Work Health and Safety Regulation 2011	Project Manager
Site Audit Reports	Once, prior to operation	Guidelines for the Assessment of On-site Containment of Contaminated Soil National Environmental Protection (Assessment of Site Contamination) Amendment Measure 2013 (No. 1) Guidelines for the NSW Site Auditor Scheme (Second Edition) (Department of Environment and Conservation 2006)	Environment and Sustainability Manager
Unexpected contaminated land or asbestos find	As required	Unexpected contaminated land or asbestos find procedure	Environment and Sustainability Manager

8. Review and improvement

8.1. Continuous improvement

Continuous improvement of this Plan will be achieved by the ongoing evaluation of environmental management performance against environmental policies, objectives and targets for the purpose of identifying opportunities for improvement.

The continuous improvement process will be designed to:

- Identify areas of opportunity for improvement of environmental management and performance,
- Determine the cause or causes of non-conformances and deficiencies,
- Develop and implement a plan of corrective and preventative action to address any non-conformances and deficiencies,
- Verify the effectiveness of the corrective and preventative actions,
- Document any changes in procedures resulting from process improvement, and
- Make comparisons with objectives and targets.

8.2. CLMP update and amendment

The processes described in Section 3.9 to Section 3.13 of the CEMP may result in the need to update or revise this Plan. This will occur as needed.

Only the Environment and Sustainability Manager, or delegate, has the authority to change any of the environmental management documentation.

A copy of the updated plan and changes will be distributed to all relevant stakeholders in accordance with the approved document control process – refer to Section 3.11.2 of the CEMP.

Annexure A Conditions of Approval and Revised Environmental Mitigation Measures relevant to this Plan

Other relevant Conditions of Approval relevant to the development of this Plan.

CoA No.	Condition Requirements	Document Reference
E181	A Site Contamination Report, documenting the outcomes of Phase 1 and Phase 2 contamination assessments of land upon which the Project is to be carried out, that is suspected, or known to be, contaminated is to be prepared by a suitably qualified and experienced person in accordance with guidelines made or approved under the <i>Contaminated Land Management Act 1997</i> (NSW).	Section 6.1.3 and 6.3
E182	If a Site Contamination Report prepared under Condition E181 finds such land contains contamination, a site audit is required to determine the suitability of a site for a specified use. If a site audit is required, a Site Audit Statement and Site Audit Report must be prepared by a NSW EPA Accredited Site Auditor. Contaminated land must not be used for the purpose approved under the terms of this approval until a Site Audit Statement is obtained that declares the land is suitable for that purpose and any conditions on the Site Audit Statement have been complied with.	Section 6.1.7 and 6.3
E183	A copy of the Site Audit Statement and Site Audit Report must be submitted to the Secretary and relevant council for information no later than one (1) month prior to the commencement of operation.	Section 6.1.7 and 6.3
E184	An Unexpected Contaminated Land and Asbestos Finds Procedure must be prepared and must be followed should unexpected contaminated land or asbestos be excavated or otherwise discovered during construction.	<i>Appendix 2: Unexpected Contaminated Land and Asbestos Finds Procedure</i>
E185	The Unexpected Contaminated Land and Asbestos Finds Procedure must be implemented throughout construction.	<i>Appendix 2: Unexpected Contaminated Land and Asbestos Finds Procedure</i>

Revised Environmental Mitigation Measures relevant to the development of this Plan.

Ref. No.	Commitment	Document reference
CM01	Potentially contaminated areas directly affected by the project will be investigated and managed in accordance with the requirements of guidance endorsed under section 105 of the Contaminated Land Management Act 1997 (NSW) (CLM Act). This includes further investigations in areas of potential contamination identified in the project footprint. If contamination posing a risk to human or ecological receptors is identified, a Remediation Action Plan (RAP) will be prepared.	Section 6.1.1 and 6.1.4
CM02	Asbestos handling and management will be undertaken in accordance with an Asbestos Management Plan (or similar prepared in accordance with relevant legislation, regulations and codes of practice) as described in Chapter 23 (Resource use and waste minimisation) of the EIS.	Asbestos Management Plan (AMP)

Ref. No.	Commitment	Document reference
CM03	A hazardous materials assessment will be carried out prior to and during the demolition of buildings. Demolition works will be undertaken in accordance with the relevant Australian Standards and relevant NSW WorkCover Codes of Practice, including the Work Health and Safety Regulation 2011 (NSW).	Section 7.3 Construction Work Health and Safety (WHS) Management Plan
CM04	The Construction Waste Management Plan for the project, prepared as described in Chapter 23 (Resource use and waste minimisation) of the EIS, will include procedures for handling and storing potentially contaminated substances.	Waste Management Plan (WMP)
CM05	Stockpile management procedures will be implemented to control dust, odour and cross contamination.	Soil and Surface Water Management Plan (SSWMP)
CM06	The discovery of previously unidentified contaminated material will be managed in accordance with an unexpected contaminated lands discovery procedure, as outlined in the Guideline for the Management of Contamination (RMS 2013) and detailed in the CEMP. The procedure will include: <ul style="list-style-type: none"> ▪ Cease work in the vicinity ▪ Initial assessment by an appropriately qualified environmental consultant ▪ Further assessment and management of contamination, if confirmed, in accordance with section 105 of the CLM Act. 	Annexure B
CM07	A Construction Soil and Water Management Plan will be prepared for the project including procedures to minimise the interaction of stormwater with contaminated land, including acid sulfate soils, and manage potentially contaminated stormwater runoff, as described in Chapter 15 (Soil and water quality) of the EIS.	SSWMP
CM08	Measures identified in Chapter 25 (Hazard and risk) of the EIS will be implemented to appropriately store contaminated materials and materials with the potential to cause contamination and reduce the potential for environmental contamination due to spills and leaks.	WHS Management Plan
RW2	Wastes will be managed and disposed of in accordance with relevant NSW legislation and government policies.	WMP
RW3	A Construction Waste Management Plan will be prepared as part of the CEMP and regularly updated during detailed design and construction, detailing appropriate procedures for waste management. The plan will include the waste management measures described in this EIS.	WMP
RW4	Wastes will be managed using the waste hierarchy principles of: <ul style="list-style-type: none"> ▪ Avoidance of unnecessary resource consumption to reduce the quantity of waste being generated ▪ Recovery of resources for reuse onsite or offsite for the same or similar use, without reprocessing ▪ Recovery of resources through recycling and reprocessing so that waste can be processed into a similar non-waste product and reused ▪ Disposal of residual waste. 	WMP
RW5	Resource recovery will be applied to the management of construction waste and will include: <ul style="list-style-type: none"> ▪ Recovery of resources for reuse-reusable materials generated by the project will be segregated for reuse on site, or off site where possible, including the reuse of the major waste streams (VENM) 	WMP

Ref. No.	Commitment	Document reference
	<ul style="list-style-type: none"> ▪ Recovery of resources for recycling - recyclable resources (such as metals, plastics and other recyclable materials) generated during construction and demolition ▪ Resources will be segregated for recycling and sent to an appropriate recycling facility for processing ▪ Recovery of resources for reprocessing - cleared vegetation will be mulched or chipped. 	
RW6	Options identified for the offsite reuse of waste will comply with relevant NSW EPA resource recovery exemptions and requirements.	WMP
RW7	The Construction Waste Management Plan will document anticipated volumes of spoil that will be generated by the Project, spoil storage locations within Project sites and likely spoil disposal sites. The Construction Waste Management Plan and spoil reuse opportunities will be regularly reviewed and updated during detailed design and Project construction.	WMP
RW8	The Project will reuse or recycle around 95 per cent of uncontaminated spoil generated for beneficial purposes, either within the Project or at other locations in accordance with the Project spoil management hierarchy.	WMP
RW9	Suitable areas will be identified to allow for contingency management of unexpected waste materials, including contaminated materials. Suitable areas will be required to be hardstand or lined areas that are appropriately stabilised and bunded, with sufficient area for stockpile storage.	WMP
RW10	The discovery of previously unidentified contaminated material will be managed in accordance with an unexpected contaminated lands discovery procedure, as outlined in the Guideline for the Management of Contamination (RMS 2013) and detailed in the CEMP.	Annexure B
RW11	Spoil stockpiles will be provided with appropriate environmental controls and managed to reduce potential impacts associated with dust generation, erosion and sedimentation.	SSWMP
RW13	An asbestos survey will be undertaken of buildings to be demolished as part of the project in accordance with an Asbestos Management Plan as part of the Work Health and Safety Plan. The survey will be conducted by a suitably qualified person.	Section 7.3
RW14	Asbestos handling and management will be undertaken in accordance with an Asbestos Management Plan (or similar) prepared in accordance with relevant legislation, regulation and codes of practice as described in Chapter 23 (Resource use and waste minimisation) of the EIS. Adjacent communities will be provided with advance notice about potential hazards.	AMP Communication Strategy

Annexure B Unexpected Contaminated Land and Asbestos Finds Procedure

1. Introduction

1.1. Purpose

This procedure describes how to manage unexpected encounters of land that contains (or is suspected of containing) substances that are actually (or potentially) hazardous to health or the environment. Contaminants may include:

- Hydrocarbons
- Polycyclic aromatic hydrocarbons
- Polychlorinated biphenyls (PCBs) and pesticides
- Heavy metals such as lead, arsenic, cadmium and mercury
- Asbestos containing material (ACM)
- Biologically pathogenic materials and waste
- Acid sulphate soils (ASS).

This procedure has been prepared to meet the requirements of the CoA, specifically CoA E184 which states: An Unexpected Contaminated Land and Asbestos Finds Procedure must be prepared and must be followed should unexpected contaminated land or asbestos be excavated or otherwise discovered during construction.

CoA E185 requires that the Unexpected Contaminated Land and Asbestos Finds Procedure must be implemented throughout construction.

The Unexpected Contaminated Land and Asbestos Finds Procedure has been broken up into two flow charts.

1.2. Sub-plans

Further information regarding the Unexpected Contaminated Land and Asbestos Finds Procedure can be found in the following sub-plans of the CEMP;

- Contaminated Land Management Plan
- Asbestos Management Plan

2. Reporting

A record of the unexpected finds will be maintained by JCL and will include the following details:

- Date, time and location of unexpected find, including depth,
- Details regarding assessment by Environment Manager (and advice from suitably qualified contamination specialist),
- Monitoring results,
- Neutralisation and treatment processes used,
- Time of excavation, reuse or disposal of material,
- Volume of material excavated, and
- Destination of treated material (i.e. offsite or onsite disposal), including a record on a site plan.

If treated material is to be disposed of offsite, material tracking would be undertaken in accordance with the *Protection of the Environment Operations Act 1997*. Transport and disposal undertaken in accordance with the *Protection of the Environment Operations (Waste) Regulation 2005* and the Waste Classification Guidelines (EPA 2014). All contractors transporting waste from the site must be licenced to transport the classification of waste and must only dispose of the waste at a facility that is licenced to accept the waste classification.

If treated material is to be reused onsite, refer to the Contaminated Land Management Plan for Remediation Action Plan requirements.

Figure 1 Unexpected Contamination Finds Procedure Flowchart

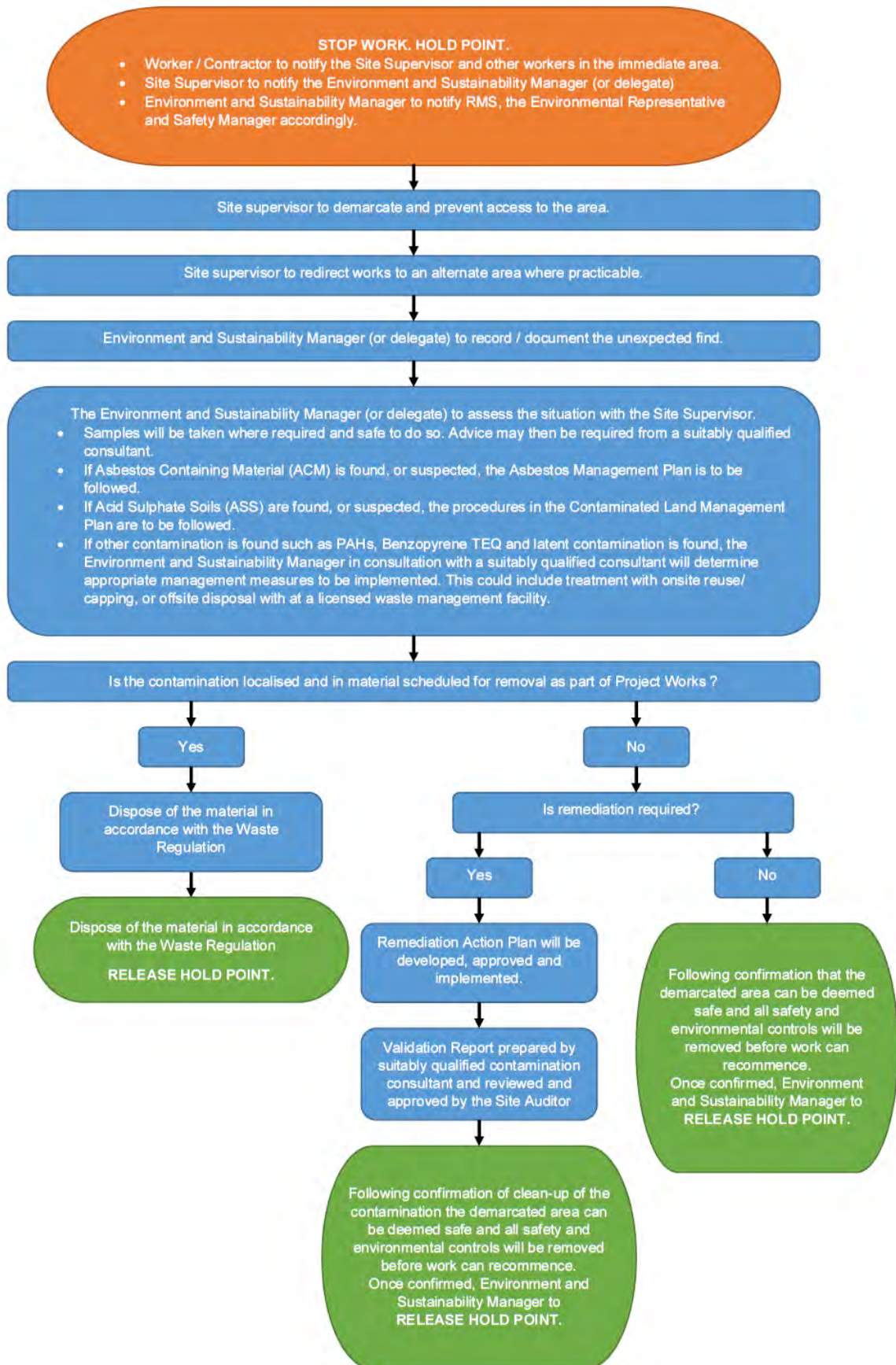
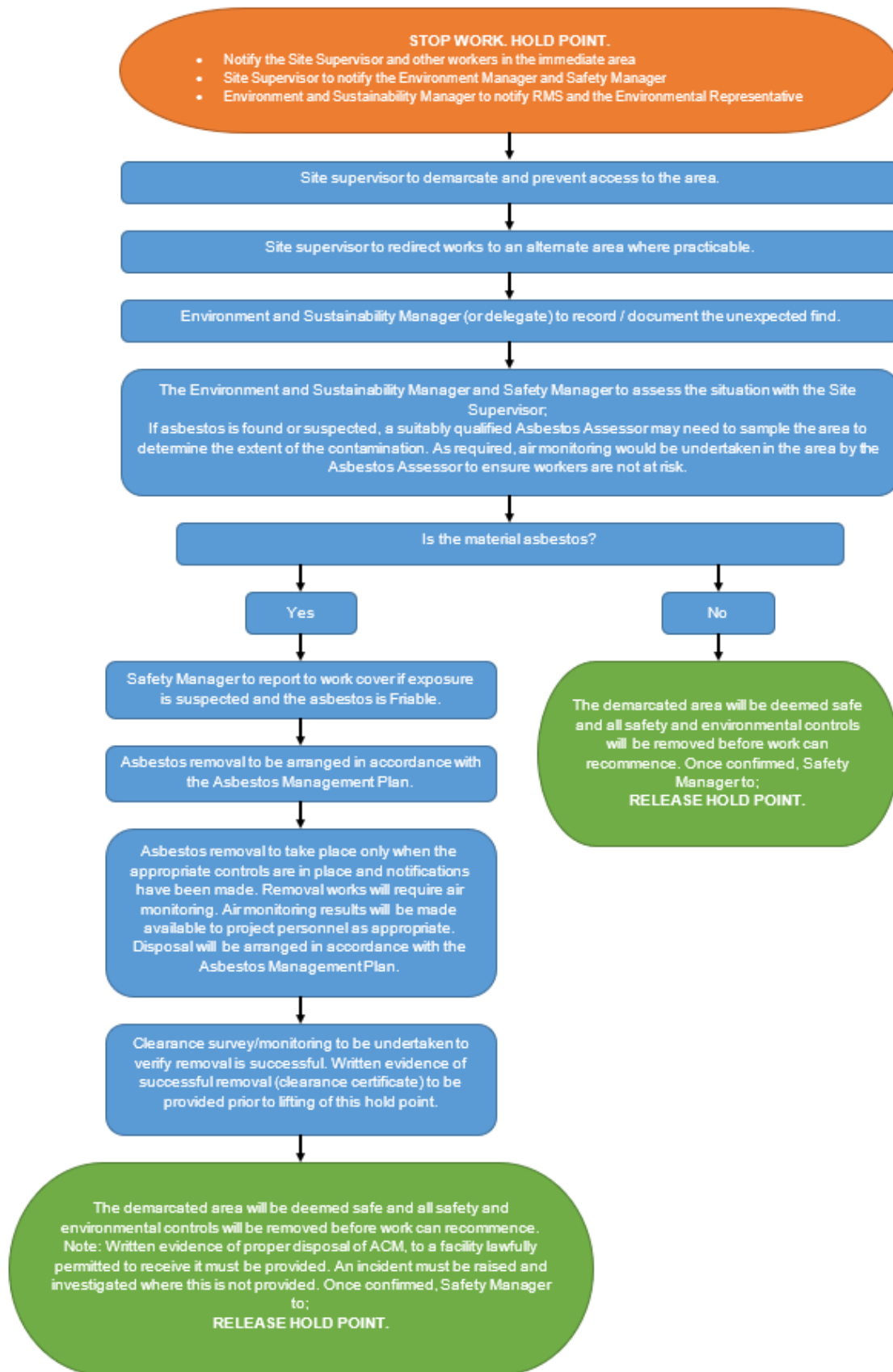

Figure 2 Unexpected Asbestos Finds Procedure Flowchart



Annexure D Baseline ESCPs

INSTRUCTIONS

BACKGROUND

The details shown on this drawing are for initial site establishment stage erosion and sediment control requirements only. Erosion and sediment controls will need to be re-assessed as works progress and revised plans will be required (or these plan can be updated).

This Erosion and Sediment Control Plan (ESCP) has been prepared in accordance with best-practice principles, generally following the guidelines contained in the Blue Book Volumes 1 and 2D (Landcom, 2004 and DECC, 2008).

Erosion Hazard Assessment:

RUSLE = R x K x LS x P x C

- R = Rainfall factor (3,480)
- K = Soil erodibility factor (0.05 for Disturbed/unknown terrain) – See SOILS section below.
- LS = Slope length and gradient factor (0.97 average adopted, using 6% slope estimate and 40m slope length)
- P = Conservation practices (1.3; hard and compacted)
- C = Ground cover (1.0, no cover).

At this site, RUSLE has been calculated as 244 t/ha/yr (Soil Loss Class 2; low erosion hazard).

The total disturbed catchment area for this stage of works is approximately 0.88ha. Therefore, based on the above, the potential soil loss is 192 t/yr.

SEDIMENT CONTROL DESIGN STANDARD

Under Blue Book standards, a sediment basin is normally required if the soil loss is > 200 t/yr per catchment. Therefore, based on the calculated soil loss a sediment basin is not required for these works. Space is also very constrained for the work area, and construction constraints would not allow for basin construction at this stage. There is also the possibility of encountering contaminated lands meaning that sediment basin construction would not be possible. In place of sediment basins, alternative sediment controls (e.g. sediment sumps, utilising excavations to capture runoff, rock filters and modular sediment traps) in conjunction with erosion control measures will be used for these works.

SOILS

The site is mapped as mostly lying on the Gynea Soil Landscape in Chapman and Murphy (1989), with a very small section (north of Byrnes Street – at the lower end closest to the Parramatta River) mapped as the Hawkesbury Soil Landscape. Most subsurface soils within the work area are expected to be consistent with the Gynea Soil Landscape, however, all surfaces have generally been extensively modified and, as such, a conservative K-factor of 0.05 has been adopted.

According to Landcom (2004), soils are likely to be dispersible at this site, so have been assumed as Type D.

OTHER DESIGN ASSUMPTIONS

- Sediment basin design (where relevant) is for 5-day, 85th percentile event for Sydney: 38.8mm.
- Assumed soil hydrological group: D (high runoff, low permeability).
- Volumetric runoff coefficient: 0.64.
- C10 runoff coefficient = 0.9.

INSTRUCTIONS

Works are to be staged in the following order with the relevant erosion and sediment controls implemented prior to and during each section of works as specified.

Initial Above Ground Building Demolition and Vegetation Removal Works (Where Applicable)

Many of the recommended controls will not be able to be installed until buildings have been removed. Therefore, soil/ground disturbance is to be minimised as much as possible until the controls for the 'Large Scale Demolition Works' (as outlined below) are in place. For the 'Initial Above Ground Building Demolition Works', erosion and sediment controls are to be implemented as specified below:

- Install site barrier fencing (or alternative measures).
- If required, establish temporary site entry/exit point(s) (Standard Drawing SD 6-14) or using rumble grids (cattle grids) or similar. These don't need to be installed if existing sealed driveways remain intact and sediment tracking is alternatively managed (e.g. through hosing of vehicle wheels). Locations shown on the plans are indicative only and can be moved to suit construction.
- Install sediment fencing (or equivalent) around the extent of the demolition and vegetation removal works in accordance with SD 6-8. If sediment fences cannot be trenched into the ground (i.e. if hardstand/pavement surfaces are present) sediment fences can be secured by placing tightly abutting sandbag or coir log bunds over the fabric to hold it down. Tightly abutting gravel bags, coir log bunds, rock filter berms, or sand bags or can also be used in place of sediment fencing where sediment fencing cannot be installed (i.e. on hardstand areas or constantly changing areas). However, gravel bags and sand bags are to be min. 2 bags high and consideration should be given to ongoing traffic and construction movements to avoid damaging the bunds. Install the required returns at 20m spacings.
- Sediment fencing is to remain in place until fabric wrapped diversion berms or impermeable noise walls are in place (where applicable) or once all earth works are contained by the boxed-out works.
- Install Drain Wardens (SD GB-01) or similar pit protection around any onsite drop inlets (to be determined onsite prior to works).
- Undertake above ground building demolition works and vegetation removal works. There is to be minimal soil disturbance during this stage of works until the controls for the 'Large Scale Demolition Works' are installed – maintain pavements, footings and grassed vegetation as much as possible.
- Exposed soils are to be covered with geofabric, black plastic or sprayed with a soil polymer (e.g. Vital Stonewall) prior to rainfall (>50% chance of rainfall > 5mm) and site closure during this stage (i.e. until the controls for the 'Large Scale Demolition Works' are installed).
- Dust suppression is to be carried out as required to minimise dust generation. Hose/spray down active works and cover disturbed surfaces where works are on not actively occurring.

Large Scale Demolition (i.e. Ground/soil disturbance) and Earthworks

- If required, establish any new temporary site entry/exit point(s) (Standard Drawing SD 6-14) or using rumble grids or similar. These don't need to be installed if existing sealed driveways remain intact and sediment tracking is alternatively managed.
- Maintain existing kerb and gutter and roadside stormwater drainage to collect and keep clean water flows outside of the work area (where applicable).
- Install sediment traps and sediment filter outlets where required and in accordance within Table 1 (i.e. rock filter outlets or modular sediment traps). This includes installing stabilised outlet points.
- Install containment/diversion bunds where required and stabilise by covering with fabric (or similar).
- Large scale demolition and initial site establishment earthworks can now commence.

The following requirements apply at all times after works have commenced:

- Contour berms are to be installed across exposed surfaces prior to rainfall to maintain slope lengths at maximum 40m intervals (where required). Diversion bunds/drains, low flow earth banks (SD 5-5), sandbag bunds or equivalent should be installed to achieve this. Locations are not shown and will change depending on current construction levels, topography and surface conditions. Note, where topography or construction works naturally limit slopes lengths to <40m, contour berms are not required.
- Due to the proximity to Parramatta River and neighbouring properties, exposed soils are to be stabilised with a soil polymer (e.g. Vital Stonewall) prior to significant rainfall (>50% chance of rainfall > 30mm) and site closure > 2 days.
- Ground surfaces across all works are to be assessed prior to rainfall and temporary drainage paths established where required to control runoff and minimise unnecessary ponding and erosion.
- Dust suppression is to be carried out as required to minimise sediments becoming air borne.
- Haul roads to be maintained in a stable and trafficable condition by re-grading as necessary.
- Treatment of dirty water is to be carried out as necessary in accordance with the site SWMP.
- Monitoring, maintenance and inspections are to be carried out regularly as required by the SWMP. Repair and maintain all controls as necessary.
- Undertake progressive stabilisation of lands (e.g. hardstand, concrete, landscaping) as final earthworks are complete in each area (rather than waiting until the completion of all works).

TABLE 1

SEDIMENT TRAP SPECIFICATIONS

- SEDIMENT TRAPS TO BE FORMED AS SEDIMENT SUMPS WITH EITHER A ROCK FILTER DAM OUTLET (SD RFD-01&02 AND PHOTO 1) OR A MODULAR SEDIMENT TRAP FILTER OUTLET (PHOTO 2 – TWO LINES OF SEDIMENT FENCE WITH STRAW BALES OR 15-25mm AGGREGATE FILL IN-BETWEEN).
- ALTERNATIVELY IF THE ABOVE FILTER OUTLETS CANNOT BE CONSTRUCTED DUE TO SITE/CONSTRUCTION CONDITIONS, TIGHTLY ABUTTING COIR LOGS OR GRAVEL BAGS ARE TO BE USED AS THE FILTER OUTLET. ENSURE THE COIR LOGS/GRAVEL BAGS ARE SECURELY HELD IN PLACE AND ARE FORMED TO THE SPECIFIED HEIGHT.
- SEDIMENT TRAP SUMPS MAY BE SPLIT UP THROUGHOUT THE CATCHMENT AS LONG AS THE FILTER OUTLETS REMAIN AS WHAT IS SPECIFIED WITHIN THIS PLAN FOR EACH OVERFLOW POINT.
- ALL FILTER OUTLET STRUCTURES ARE TO BE BUILT TO INCORPORATE A PRIMARY OUTLET (WEIR OVERFLOW/SPILLWAY) TO ENSURE OVERFLOWS ARE CONTROLLED AND ARE STABLE.
- IT IS RECOMMENDED THAT GYPSUM IS PLACED AT THE INLETS OF THE SEDIMENT TRAPS PRIOR TO RAINFALL. THIS WILL HELP TREAT DIRTY WATER.
- SEDIMENT IS TO BE REMOVED FROM SEDIMENT TRAPS AND FILTER OUTLETS REGULARLY AND FILTER AGGREGATE/STRAW BALES/SEDIMENT FENCE ETC REPLACED AS REQUIRED.

SPECIFICATIONS

DIMENSIONS	ST1	ST2	ST3	ST4	ST5	ST6
SUMP AREA (m ²) ^[1]	7	8	7	11	10	7
SUMP (FREEBOARD) DEPTH (m) ^[2]	0.4	0.4	0.4	0.4	0.4	0.4
FILTER MEDIA THICKNESS ^[3]	0.3	0.3	0.3	0.3	0.3	0.3
MINIMUM FILTER HEIGHT (m)	0.3	0.3	0.3	0.3	0.3	0.3
FILTER WIDTH (m)	2.5	3.0	2.5	4.0	3.5	2.5

- A SUMP IS TO BE FORMED UPSLOPE OF THE SEDIMENT TRAP FILTER OUTLET TO THE MINIMUM AREA AS SPECIFIED. WHERE POSSIBLE THE SUMP IS TO BE FORMED OFF-ALIGNMENT. HOWEVER, IF THIS IS NOT POSSIBLE THE SUMP MAY BE INCORPORATED AS PART OF THE EXCAVATED WORK AREA.
- A FREEBOARD DEPTH FROM THE OVERFLOW LEVEL OF THE FILTER MEDIA OUTLET TO THE BASE OF THE SUMP IS TO BE PROVIDED AS FREE STORAGE CAPACITY.
- THE FILTER MEDIA IS TO BE FORMED PREFERABLY AS AGGREGATE (15-25mm). ALTERNATIVELY STRAW BALES, COIR LOGS OR GRAVEL FILLED BAGS ARE TO BE USED IF THE ABOVE FILTERS CANNOT BE INSTALLED.



PHOTO 1: ROCK FILTER DAM EXAMPLE

MADE IN ACCORDANCE WITH THE SPECIFICATIONS SHOWN ON SD RFD-01 & 02.



PHOTO 2: MODULAR SEDIMENT TRAP EXAMPLE

MADE OF TWO ROWS OF SEDIMENT FENCE WITH A ROW OF STRAW BALES IN-BETWEEN. AGGREGATE (15-25mm) CAN BE USED IN PLACE OF THE STRAW BALES.

REV	DATE	DES.	DRN.	APP.	REVISION DETAILS	DRAWING STATUS	North	CLIENT	PROJECT TITLE	DRAWING TITLE	PROJECT NO.	SUB-PR NO.	DRAWING NO.	REV
						DESIGN BY DRAWN BY FINAL APPROVAL				WESTCONNEX STAGE 3B IRON COVE LINK CIVIL SITE	18000227	P02	ESCP001	00
00	11/06/19	A.T.	A.T.	A.M.	FINAL – FOR USE	SCALE: (on A3 Original) N/A								
B	03/06/19	A.T.	A.T.	A.M.	REVISED DRAFT – FOR CONSULTATION									
A	07/08/18	A.T.	A.T.	A.M.	DRAFT – FOR CONSULTATION									

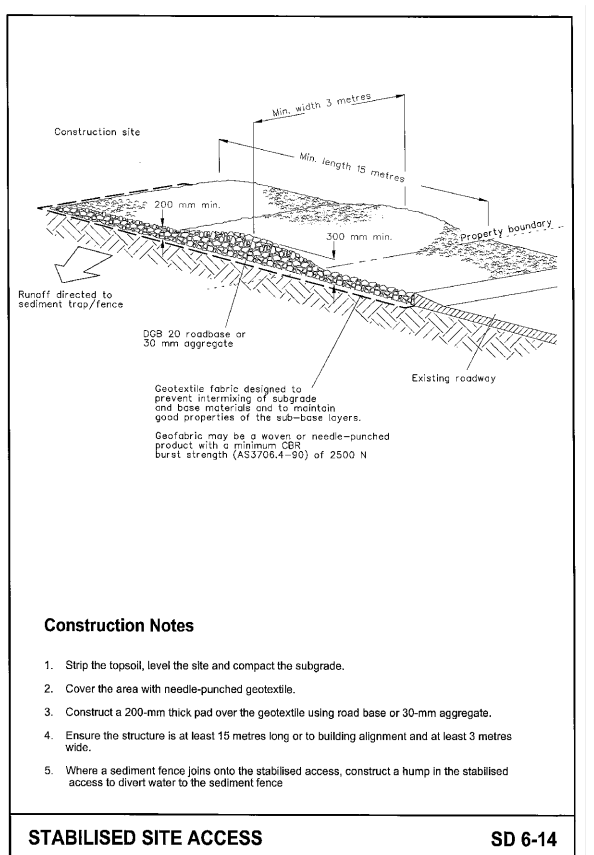
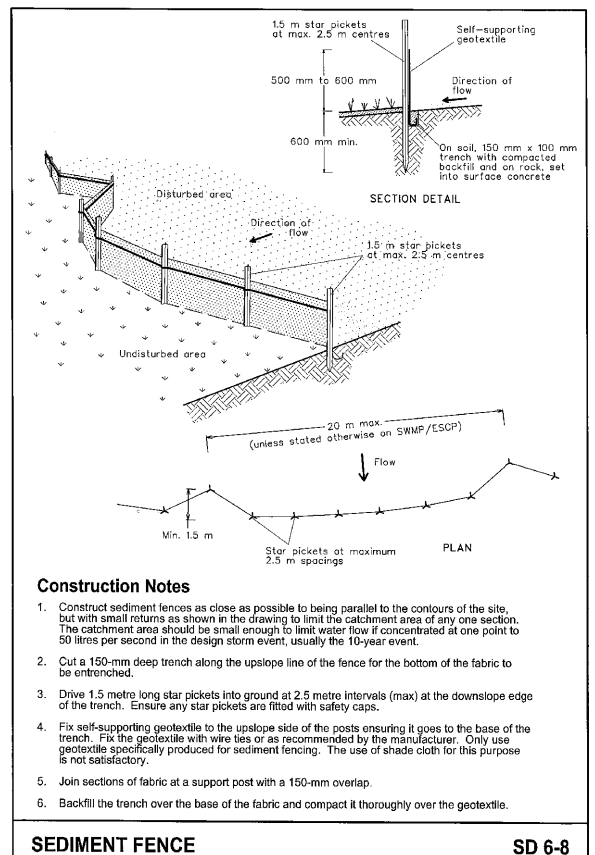
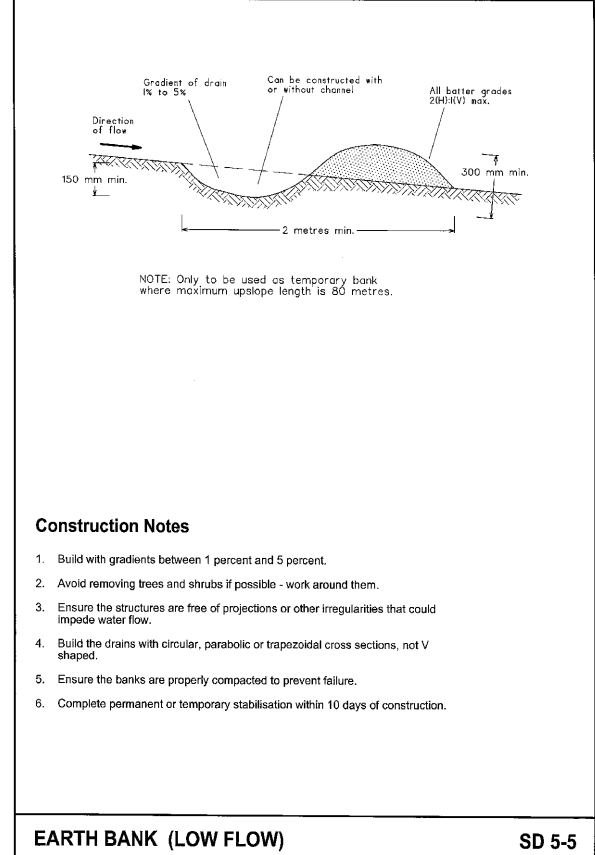
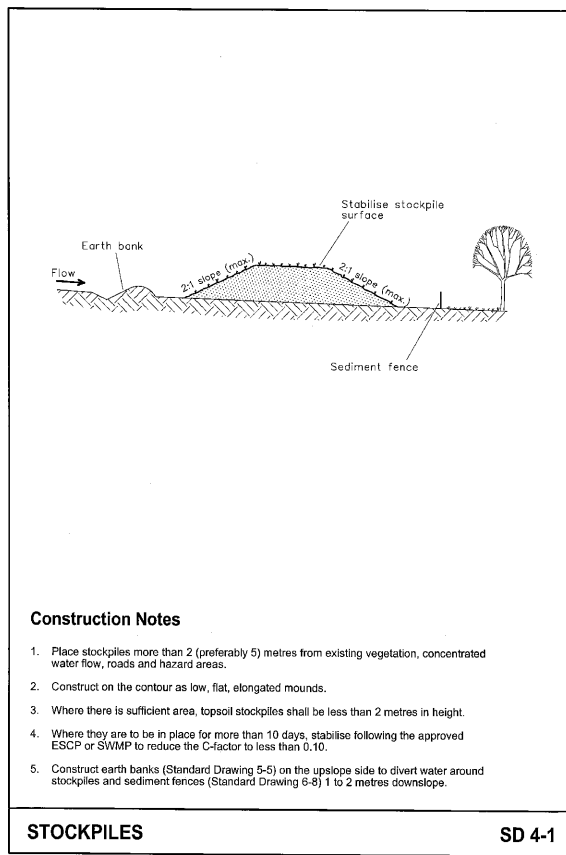

STANDARD DRAWINGS ARE FROM LANDCOM (2004).

REV	DATE	DES.	DRN.	APP.	REVISION DETAILS
00	11/06/19	A.T.	A.T.	A.M.	FINAL - FOR USE
B	03/06/19	A.T.	A.T.	A.M.	REVISED DRAFT - FOR CONSULTATION
A	07/08/18	A.T.	A.T.	A.M.	DRAFT - FOR CONSULTATION

DRAWING STATUS	
DESIGN BY	A.T.
DRAWN BY	A.T.
FINAL APPROVAL	A.M.
SCALE:	N/A
(on A3 Original)	
FINAL	

North

CLIENT

JOHN HOLLAND



PO Box 1098, Bowral, NSW, 2576
 Suites 7 & 8, 68-70 Station Street
 Bowral NSW 2576.
 (t) 02 4862 1633
 (f) 02 4862 3088
 email: reception@seec.com.au
 WWW.SEEC.COM.AU

PROJECT TITLE

**WESTCONNEX
 STAGE 3B
 IRON COVE LINK CIVIL SITE**

DRAWING TITLE			
ESCP BLUE BOOK STANDARD DRAWINGS			
PROJECT NO.	SUB-PR NO.	DRAWING NO.	REV
18000227	P02	ESCP002	00

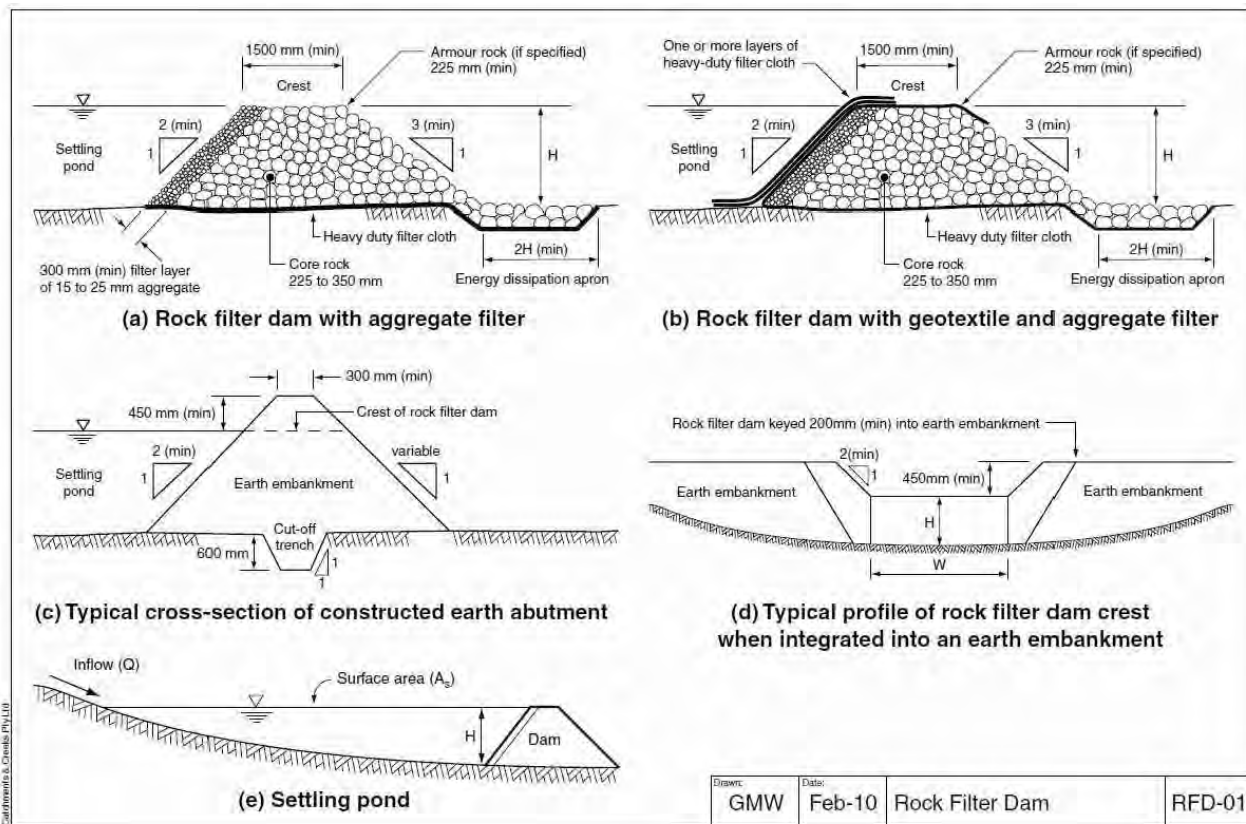

Drawn:	Date:	Project Name:	Drawing Code:
GMW	Feb-10	Rock Filter Dam	RFD-01

INSTALLATION

THE FOLLOWING A GENERAL INSTALLATION REQUIREMENTS. OPERATORS SHOULD OBTAIN INSTALLATION INSTRUCTIONS FROM THE GULLY BAG MANUFACTURER OR DISTRIBUTER.

- REFER TO APPROVED PLANS FOR LOCATION AND INSTALLATION DETAILS. IF THERE ARE QUESTIONS OR PROBLEMS WITH THE LOCATION, DIMENSIONS, OR METHOD OF INSTALLATION, CONTACT THE ENGINEER OR RESPONSIBLE ON-SITE OFFICER FOR ASSISTANCE.
- ENSURE THAT THE INSTALLATION OF THE SEDIMENT TRAP WILL NOT CAUSE UNDESIRABLE SAFETY OR FLOODING ISSUES.
- INSTALL SEDIMENT TRAP IN ACCORDANCE WITH MANUFACTURER'S INSTRUCTIONS.
- ENSURE THAT NO SEDIMENT-LADEN INFLOW IS ALLOWED TO BYPASS THE GULLY BAG UNTIL THE BAG IS EITHER FULL OF SEDIMENT, OR THE INFLOW EXCEEDS THE HYDRAULIC CAPACITY OF THE BAG.
- INSTALL APPROPRIATE SEDIMENT AND/OR FLOW CONTROLS ON THE SIDE-ENTRY SLOT (IF ANY).
- TAKE ALL NECESSARY MEASURE TO MINIMISE THE SAFETY RISK CAUSED BY THE STRUCTURE.

MAINTENANCE

- INSPECT ALL SEDIMENT TRAPS DAILY AND IMMEDIATELY AFTER RUNOFF-PRODUCING RAINFALL. MAKE REPAIRS AS NEEDED.
- REMOVE AND REPLACE THE GULLY BAG WHEN IT IS EITHER FULL OF SEDIMENT, OR IS LIKELY TO BE FULL OF SEDIMENT BEFORE THE NEXT INSPECTION, OR THE HYDRAULIC CAPACITY OF THE FILTER BAG IS EXCESSIVELY REDUCED.
- DISPOSE OF THE SEDIMENT AND FILTER BAG IN A SUITABLE MANNER THAT WILL NOT CAUSE AN EROSION OR POLLUTION HAZARD.
- ENSURE SEDIMENT DOES NOT ENTER THE STORMWATER DRAIN DURING DE-SILTING OPERATIONS AND MAINTENANCE OF THE TRAP.
- SEDIMENT ON THE ROAD MUST BE REMOVED IMMEDIATELY IF IT REPRESENTS A SAFETY HAZARD.

REMOVAL

- WHEN THE UP-SLOPE DRAINAGE AREA HAS BEEN STABILISED, REMOVE ALL MATERIALS INCLUDED DEPOSITED SEDIMENT AND DISPOSE OF IN A SUITABLE MANNER THAT WILL NOT CAUSE AN EROSION OR POLLUTION HAZARD.

Gully filter bag to be well secured to prevent movement

Where necessary, fold road side flap over grate to reduce risk of damage by traffic (do not fully block the grate)

Figure 1 - Gully filter bag

Drawn:	Date:	Project Name:	Drawing Code:
GMW	Dec-09	Gully Filter Bag	GB-01

<p>MATERIALS</p> <p>PRIMARY CORE ROCK: WELL GRADED, HARD, ANGULAR, EROSION RESISTANT ROCK, WITH MEAN SIZE AS SPECIFIED IN THE APPROVED PLAN, BUT NOT LESS THAN 225mm, OR GREATER THAN 350mm.</p> <p>ARMOUR ROCK: WELL GRADED, HARD, ANGULAR, EROSION RESISTANT ROCK, WITH MEAN SIZE AS SPECIFIED IN THE APPROVED PLAN, BUT NOT LESS THAN 225mm.</p> <p>AGGREGATE FILTER: 15 TO 25mm CLEAN AGGREGATE.</p> <p>GEOTEXTILE FILTER FABRIC: HEAVY-DUTY NON-WOVEN, NEEDLE-PUNCHED FILTER FABRIC, MINIMUM BIDIM A34 OR EQUIVALENT.</p> <p>INSTALLATION</p> <ol style="list-style-type: none"> REFER TO APPROVED PLANS FOR LOCATION AND CONSTRUCTION DETAILS. IF THERE ARE QUESTIONS OR PROBLEMS WITH THE LOCATION, OR METHOD OF INSTALLATION, CONTACT THE ENGINEER OR RESPONSIBLE ON-SITE OFFICER FOR ASSISTANCE. CLEAR THE FOUNDATION AREA OF THE ROCK FILTER DAM OF WOODY VEGETATION AND ORGANIC MATTER. DELAY CLEARING THE UP-SLOPE POND AREA UNTIL THE DAM IS FORMED AND IS ABLE TO ACT AS A SUITABLE SEDIMENT TRAP. OTHERWISE AN ALTERNATIVE TEMPORARY DOWNSTREAM SEDIMENT TRAP MAY BE REQUIRED DURING CONSTRUCTION OF THE ROCK FILTER DAM. IF SPECIFIED ON THE PLANS, EXCAVATE A CUT-OFF TRENCH ALONG THE CENTRE-LINE OF THE DAM AND EARTH ABUTMENTS (IF ANY). COVER THE FOUNDATION AREA AND CUT-OFF TRENCH WITH HEAVY-DUTY FILTER FABRIC BEFORE BACKFILLING WITH THE CORE ROCK. OVERLAP ADJOINING FABRIC SHEETS A MINIMUM OF 600mm. CONSTRUCT THE ASSOCIATED EARTH ABUTMENT (IF ANY). ALL CUT AND FILL SLOPES SHOULD BE 2:1(H:V) OR FLATTER. THE 	<p>DOWNSTREAM FACE OF EARTH ABUTMENTS SHOULD BE 3:1(H:V) OR FLATTER. EARTH ABUTMENTS SHOULD BE CONSTRUCTED OF WELL-COMPACTED, EROSION RESISTANT SOIL THAT IS FREE OF VEGETATION AND ROOTS. OVERFILL EARTH ABUTMENTS 150mm TO ALLOW FOR SETTLEMENT.</p> <ol style="list-style-type: none"> PLACE THE CORE ROCK FOR THE ROCK FILTER DAM. ENSURE THE UPSTREAM FACE IS 2:1(H:V) OR FLATTER, AND THE DOWNSTREAM FACE IS 3:1(H:V) OR FLATTER. ENSURE THE ROCK IS MACHINE PLACED WITH THE SMALLER ROCKS WORKED INTO THE VOIDS OF THE LARGER ROCKS. IF SPECIFIED, CONSTRUCT THE SPILLWAY SECTION USING THE SPECIFIED ARMOUR ROCK. THE SPILLWAY SHOULD HAVE A MINIMUM PROFILE DEPTH OF 300mm. THE SPILLWAY WEIR CREST MUST BE LEVEL ACROSS ITS FULL WIDTH. THE MAXIMUM LONGITUDINAL SLOPE OF THE ROCK SPILLWAY SHOULD BE 3:1(H:V). THE MINIMUM THICKNESS OF ARMOUR ROCK PROTECTION SHOULD BE 500mm, OR TWICE THE NOMINAL ROCK SIZE, WHICHEVER IS THE GREATER. ENSURE THE SPILLWAY OUTLET SECTION EXTENDS DOWNSTREAM PAST THE TOE OF THE FORMED EMBANKMENT UNTIL STABLE CONDITIONS ARE REACHED, OR A DISTANCE EQUAL TO THE HEIGHT OF THE DAM, WHICHEVER IS THE GREATER. THE EDGES OF THE SPILLWAY SHOULD BE LEFT FLUSH WITH THE SURROUNDING GROUND. INSTALL THE SPECIFIED FILTER (AGGREGATE AND/OR FILTER CLOTH) ON THE UPSTREAM FACE OF THE ROCK FILTER DAM. IF FILTER CLOTH IS USED, THEN: <ol style="list-style-type: none"> EXTEND THE FABRIC OVER THE CREST OF THE ROCK FILTER DAM INTO THE SPILLWAY CHUTE; CONSIDER THE PLACEMENT OF SEVERAL LAYERS OF OVERLAPPING FABRIC, THUS ALLOWING EACH LAYER TO BE REMOVED INDIVIDUALLY ONCE THE FABRIC BECOMES BLOCKED WITH SEDIMENT. 	<ol style="list-style-type: none"> CLEAR THE SETTling POND AREA OF WOODY VEGETATION AND ORGANIC MATTER TO THE DIMENSIONS SPECIFIED WITHIN THE PLANS. WHERE NECESSARY, EXCAVATE THE UPSTREAM SETTling POND AND/OR SEDIMENT STORAGE PIT IN ACCORDANCE WITH THE APPROVED PLANS. EXCAVATED PITS TYPICALLY HAVE SIDE SLOPES OF 2:1(H:V) OR FLATTER UNLESS STEEPER SLOPES ARE KNOWN TO BE STABLE. STABILISE ANY ASSOCIATED EARTH EMBANKMENTS IMMEDIATELY AFTER CONSTRUCTION THROUGH APPROPRIATE COMPACTION, VEGETATION AND/OR EROSION CONTROL MATTING. ESTABLISH ALL NECESSARY UP-SLOPE DRAINAGE CONTROL MEASURES TO ENSURE THAT SEDIMENT-LADEN RUNOFF IS APPROPRIATELY DIRECTED INTO THE SEDIMENT TRAP. TAKE ALL NECESSARY MEASURE TO MINIMISE THE SAFETY RISK CAUSED BY THE STRUCTURE. <p>MAINTENANCE</p> <ol style="list-style-type: none"> CHECK ALL ROCK FILTER DAMS AFTER EACH RUNOFF EVENT AND MAKE REPAIRS IMMEDIATELY. INSPECT ALL ROCK AND EARTH EMBANKMENTS FOR UNDERCUTTING OR UNDESIRABLE SEEPAGE FLOWS. IDEALLY, ROCK FILTER DAMS SHOULD DISCHARGE (FROM FULL) OVER NO LESS THAN 8 HOURS. IF DRAINAGE IS TOO RAPID, THEN ADDITIONAL FILTER AGGREGATE MAYBE REQUIRED TO ACHIEVE OPTIMUM HYDRAULIC PERFORMANCE. IF FLOW THROUGH THE STRUCTURE IS REDUCED TO AN UNACCEPTABLE LEVEL, THE 	<p>UPSTREAM FILTER MEDIUM (AGGREGATE OR FILTER CLOTH) SHOULD BE REMOVED AND REPLACED.</p> <ol style="list-style-type: none"> IF A GREATER DEGREE OF WATER TREATMENT (FILTRATION) IS REQUIRED, EXTRA GEOTEXTILE FILTER FABRIC SHOULD BE PLACED OVER THE UPSTREAM FACE OF THE STRUCTURE. CHECK THE STRUCTURE AND DOWNSTREAM CHANNEL BANKS FOR DAMAGE FROM OVERTOPPING FLOWS. MAKE REPAIRS AS NECESSARY. IMMEDIATELY REPLACE ANY ROCK DISPLACED FROM THE SPILLWAY. REMOVE SEDIMENT AND RESTORE ORIGINAL SEDIMENT STORAGE VOLUME WHEN COLLECTED SEDIMENT EXCEEDS 10% OF THE SPECIFIED STORAGE VOLUME. DISPOSE OF SEDIMENT AND DEBRIS IN A MANNER THAT WILL NOT CREATE AN EROSION OR POLLUTION HAZARD. <p>REMOVAL</p> <ol style="list-style-type: none"> WHEN THE UP-SLOPE DRAINAGE AREA HAS BEEN STABILISED, REMOVE ALL MATERIALS INCLUDED DEPOSITED SEDIMENT AND DISPOSE OF IN A SUITABLE MANNER THAT WILL NOT CAUSE AN EROSION OR POLLUTION HAZARD. ALL WATER AND SEDIMENT SHOULD BE REMOVED FROM THE SETTling POND PRIOR TO THE DAM'S REMOVAL. DISPOSE OF SEDIMENT AND WATER IN A MANNER THAT WILL NOT CREATE AN EROSION OR POLLUTION HAZARD. BRING THE DISTURBED AREA TO A PROPER GRADE, THEN SMOOTH, COMPACT AND STABILISE AND/OR REVEGETATE AS REQUIRED TO MINIMISE THE EROSION HAZARD.
--	--	--	--

Drawn:	Date:	Project Name:	Drawing Code:
GMW	Apr-10	Rock Filter Dam	RFD-02

STANDARD DRAWINGS RFD-01, RFD-02 AND GB-01 ARE COPYRIGHT CATCHMENTS AND CREEKS AND REPRODUCED FROM IECA (2008).

<table border="1"> <thead> <tr> <th>REV</th> <th>DATE</th> <th>DES.</th> <th>DRN.</th> <th>APP.</th> <th>REVISION DETAILS</th> </tr> </thead> <tbody> <tr> <td>00</td> <td>11/06/19</td> <td>A.T.</td> <td>A.T.</td> <td>A.M.</td> <td>FINAL - FOR USE</td> </tr> <tr> <td>B</td> <td>03/06/19</td> <td>A.T.</td> <td>A.T.</td> <td>A.M.</td> <td>REVISED DRAFT - FOR CONSULTATION</td> </tr> <tr> <td>A</td> <td>07/08/18</td> <td>A.T.</td> <td>A.T.</td> <td>A.M.</td> <td>DRAFT - FOR CONSULTATION</td> </tr> </tbody> </table>	REV	DATE	DES.	DRN.	APP.	REVISION DETAILS	00	11/06/19	A.T.	A.T.	A.M.	FINAL - FOR USE	B	03/06/19	A.T.	A.T.	A.M.	REVISED DRAFT - FOR CONSULTATION	A	07/08/18	A.T.	A.T.	A.M.	DRAFT - FOR CONSULTATION	<table border="1"> <thead> <tr> <th colspan="2">DRAWING STATUS</th> </tr> </thead> <tbody> <tr> <td>DESIGN BY</td> <td>A.T.</td> </tr> <tr> <td>DRAWN BY</td> <td>A.T.</td> </tr> <tr> <td>FINAL APPROVAL</td> <td>A.M.</td> </tr> <tr> <td>SCALE:</td> <td>N/A</td> </tr> <tr> <td>(on A3 Original)</td> <td></td> </tr> <tr> <td colspan="2" style="text-align: center; font-size: 24px; font-weight: bold;">FINAL</td> </tr> </tbody> </table>	DRAWING STATUS		DESIGN BY	A.T.	DRAWN BY	A.T.	FINAL APPROVAL	A.M.	SCALE:	N/A	(on A3 Original)		FINAL		<p>North</p> <p>CLIENT</p> <div style="display: flex; justify-content: space-around; align-items: center;"> </div> <p>PO Box 1098, Bowral, NSW, 2576 Suites 7 & 8, 68-70 Station Street Bowral NSW 2576. (t) 02 4862 1633 (f) 02 4862 3088 email: reception@seec.com.au WWW.SEEC.COM.AU</p>	<p>PROJECT TITLE</p> <p style="text-align: center; font-weight: bold;">WESTCONNEX STAGE 3B IRON COVE LINK CIVIL SITE</p>	<table border="1"> <thead> <tr> <th colspan="4">DRAWING TITLE</th> </tr> <tr> <th colspan="4" style="text-align: center;">ESCP IECA STANDARD DRAWINGS</th> </tr> <tr> <th>PROJECT NO.</th> <th>SUB-PR NO.</th> <th>DRAWING NO.</th> <th>REV</th> </tr> </thead> <tbody> <tr> <td style="text-align: center;">18000227</td> <td style="text-align: center;">P02</td> <td style="text-align: center;">ESCP003</td> <td style="text-align: center;">00</td> </tr> </tbody> </table>	DRAWING TITLE				ESCP IECA STANDARD DRAWINGS				PROJECT NO.	SUB-PR NO.	DRAWING NO.	REV	18000227	P02	ESCP003	00
REV	DATE	DES.	DRN.	APP.	REVISION DETAILS																																																					
00	11/06/19	A.T.	A.T.	A.M.	FINAL - FOR USE																																																					
B	03/06/19	A.T.	A.T.	A.M.	REVISED DRAFT - FOR CONSULTATION																																																					
A	07/08/18	A.T.	A.T.	A.M.	DRAFT - FOR CONSULTATION																																																					
DRAWING STATUS																																																										
DESIGN BY	A.T.																																																									
DRAWN BY	A.T.																																																									
FINAL APPROVAL	A.M.																																																									
SCALE:	N/A																																																									
(on A3 Original)																																																										
FINAL																																																										
DRAWING TITLE																																																										
ESCP IECA STANDARD DRAWINGS																																																										
PROJECT NO.	SUB-PR NO.	DRAWING NO.	REV																																																							
18000227	P02	ESCP003	00																																																							

This drawing is subject to COPYRIGHT ©. The information on this drawing remains the property of SEEC.

LEGEND

- - - SITE BOUNDARY
- ← TRAFFICABLE HUMP ACROSS SITE ACCESS POINT TO MAINTAIN CLEAN AND DIRTY WATER SEPARATION
- LIVE STORMWATER PIT ^[1]
- PIT PROTECTION (DRAIN WARDENS OR SD 6-12) ^[1]
- STABILISED SITE ACCESS (SD 6-14) OR PROVIDE SEALED, STABLE SURFACES (E.G. EXISTING CONCRETE DRIVEWAYS) OR RUMBLE/CATTLE GRIDS
- ASSUMED CLEAN FLOW DIRECTION FOR CURRENT STAGE OF WORKS
- ASSUMED DIRTY FLOW DIRECTION FOR CURRENT STAGE OF WORKS
- STAGE 1 SITE AREA
- LIVE TRAFFIC VICTORIA ROAD - STAGE 1
- NO DISTURBANCE - MAINTAIN PAVEMENT
- POTENTIAL STOCKPILE AREA (SD 4-1) - INDICATIVE LOCATION
- SEDIMENT TRAP AND FILTER OUTLET ^[2]
- HOLDING POND
- STABILISED/HARDSTAND SURFACES ^[3]
- TEMPORARY PIPE
- ↘ OVERFLOW INTO STORMWATER OR ONTO A STABILISED SUITABLE DRAINAGE SURFACE
- SEDIMENT FENCE OR ALTERNATIVE (SD 6-8) ^[4]
- DIVERSION BUND (SD 5-5) ^[4]

- [1] PIT LOCATIONS ARE APPROXIMATE ONLY AND NOT ALL LOCATIONS ARE SHOWN. EXACT LOCATIONS WILL NEED TO BE CONFIRMED ONSITE AND WITH THE ENGINEERING DRAINAGE PLANS.
- [2] SEDIMENT TRAP TO BE INSTALLED AS A SUMP WITH A ROCK FILTER DAM, A MODULAR SEDIMENT FENCE WITH STRAW/AGGREGATE FILTER OR SIMILAR OUTLET) - REFER TO TABLE 1 ON ESCP001 FOR DETAILS AND TO STANDARD DRAWINGS SD RFD-01&02 AND PHOTOS 1 & 2 FOR OUTLET OPTIONS. WHERE THE FILTER OUTLET IS LOCATED BEHIND A PERIMETER SEDIMENT FENCE, THE PERIMETER SEDIMENT FENCE CAN BE USED AS THE OUTER SEDIMENT FENCE (I.E. ONLY TWO ROWS OF SEDIMENT FENCE ARE REQUIRED NOT THREE).
- [3] STABILISED/HARDSTAND SURFACES ARE TO BE MAINTAINED. EXISTING PAVEMENTS (E.G. CONCRETE, ASPHALT OR SIMILAR) CAN BE MAINTAINED WHERE SUITABLE FOR THIS PURPOSE. ALTERNATIVELY HOT MIX, AGGREGATE, CRUSHED ROCK/DGB STABILISED WITH A HEAVY DUTY TRAFFICABLE POLYMER OR SIMILAR CAN BE IMPLEMENTED.
- [4] WHERE THERE IS A NOISE WALL PRESENT THAT IS SET INTO THE GROUND FORMING A CONTINUOUS IMPERMEABLE BARRIER, SEDIMENT FENCING OR DIVERSION BUNDS ARE NOT REQUIRED.

SD - BLUE BOOK STANDARD DRAWING (LANDCOM, 2004)
 IECA SD - IECA STANDARD DRAWING (IECA, 2008)
 (REFER TO SEEC DRAWINGS 18000227_P02_ESCP001-003)

SLOPE LENGTHS ARE TO BE MAINTAINED AT MAXIMUM 40m INTERVALS ACROSS ALL EXPOSED SURFACES DURING RAINFALL (>50% CHANCE OF RAINFALL >10mm). EARTH CONTOUR BERMS, SANDBAG BUNDS OR SIMILAR IMPLEMENTED PRIOR TO RAINFALL CAN BE USED TO ACHIEVE THIS. NOTE THAT CURRENTLY IN MANY LOCATIONS THE NATURAL DIRECTION OF FALL ACROSS THE SITE ALREADY RESTRICTS SLOPE LENGTHS TO 40m OR LESS. HOWEVER, THIS WILL STILL NEED TO BE RE-ASSESSED AS WORKS PROGRESS AND LEVELS CHANGE.

REFER TO ESCP001-003 FOR INSTRUCTIONS, STANDARD DRAWINGS AND BACKGROUND INFORMATION.

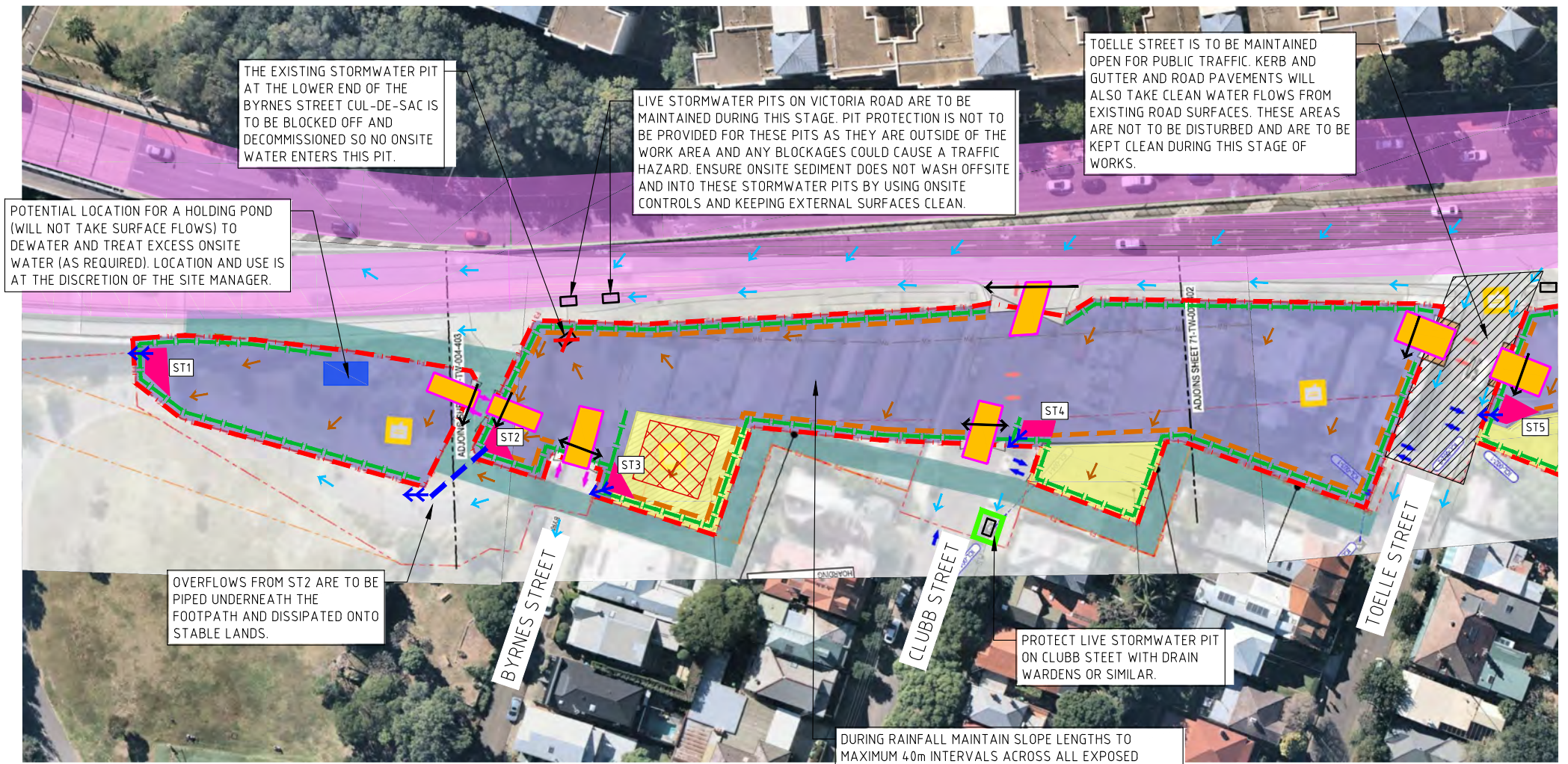

REV	DATE	DES.	DRN.	APP.	REVISION DETAILS
00	11/06/19	A.T.	A.T.	A.M.	FINAL - FOR USE
B	03/06/19	A.T.	A.T.	A.M.	REVISED DRAFT - FOR CONSULTATION
A	07/08/18	A.T.	A.T.	A.M.	DRAFT - FOR CONSULTATION

DRAWING STATUS	
DESIGN BY	A.T.
DRAWN BY	A.T.
FINAL APPROVAL	A.M.
SCALE:	1:1250
FINAL	

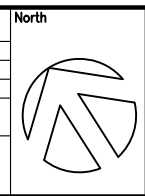

CLIENT

JOHN HOLLAND

CPB CONTRACTORS

SEEC

PO Box 1098, Bowral, NSW, 2576
 Suites 7 & 8, 68-70 Station Street
 Bowral NSW 2576.
 (t) 02 4862 1633
 (f) 02 4862 3088
 email: reception@seec.com.au
 WWW.SEEC.COM.AU











PROJECT TITLE

**WESTCONNEX
 STAGE 3B
 IRON COVE LINK CIVIL SITE**

DRAWING TITLE			
EROSION AND SEDIMENT CONTROL PLAN FOR INITIAL SITE ESTABLISHMENT			
PROJECT NO.	SUB-PR NO.	DRAWING NO.	REV
18000227	P02	ESCP101	00

This drawing is subject to COPYRIGHT ©. The information on this drawing remains the property of SEEC.

LEGEND

-  SITE BOUNDARY
-  TRAFFICABLE HUMP ACROSS SITE ACCESS POINT TO MAINTAIN CLEAN AND DIRTY WATER SEPARATION
-  LIVE STORMWATER PIT ^[1]
-  PIT PROTECTION (DRAIN WARDENS OR SD 6-12) ^[1]
-  STABILISED SITE ACCESS (SD 6-14) OR PROVIDE SEALED, STABLE SURFACES (E.G. EXISTING CONCRETE DRIVEWAYS) OR RUMBLE/CATTLE GRIDS
-  ASSUMED CLEAN FLOW DIRECTION FOR CURRENT STAGE OF WORKS
-  ASSUMED DIRTY FLOW DIRECTION FOR CURRENT STAGE OF WORKS
-  STAGE 1 SITE AREA
-  LIVE TRAFFIC VICTORIA ROAD - STAGE 1
-  NO DISTURBANCE - MAINTAIN PAVEMENT
-  POTENTIAL STOCKPILE AREA (SD 4-1) - INDICATIVE LOCATION
-  SEDIMENT TRAP AND FILTER OUTLET ^[2]
-  HOLDING POND
-  STABILISED/HARDSTAND SURFACES ^[3]
-  TEMPORARY PIPE
-  OVERFLOW INTO STORMWATER OR ONTO A STABILISED SUITABLE DRAINAGE SURFACE
-  SEDIMENT FENCE OR ALTERNATIVE (SD 6-8) ^[4]
-  DIVERSION BUND (SD 5-5) ^[4]

- [1] PIT LOCATIONS ARE APPROXIMATE ONLY AND NOT ALL LOCATIONS ARE SHOWN. EXACT LOCATIONS WILL NEED TO BE CONFIRMED ONSITE AND WITH THE ENGINEERING DRAINAGE PLANS.
- [2] SEDIMENT TRAP TO BE INSTALLED AS A SUMP WITH A ROCK FILTER DAM, A MODULAR SEDIMENT FENCE WITH STRAW/AGGREGATE FILTER OR SIMILAR OUTLET) - REFER TO TABLE 1 ON ESCP001 FOR DETAILS AND TO STANDARD DRAWINGS SD RFD-01&02 AND PHOTOS 1 & 2 FOR OUTLET OPTIONS. WHERE THE FILTER OUTLET IS LOCATED BEHIND A PERIMETER SEDIMENT FENCE, THE PERIMETER SEDIMENT FENCE CAN BE USED AS THE OUTER SEDIMENT FENCE (I.E. ONLY TWO ROWS OF SEDIMENT FENCE ARE REQUIRED NOT THREE).
- [3] STABILISED/HARDSTAND SURFACES ARE TO BE MAINTAINED. EXISTING PAVEMENTS (E.G. CONCRETE, ASPHALT OR SIMILAR) CAN BE MAINTAINED WHERE SUITABLE FOR THIS PURPOSE. ALTERNATIVELY HOT MIX, AGGREGATE, CRUSHED ROCK/DGB STABILISED WITH A HEAVY DUTY TRAFFICABLE POLYMER OR SIMILAR CAN BE IMPLEMENTED.
- [4] WHERE THERE IS A NOISE WALL PRESENT THAT IS SET INTO THE GROUND FORMING A CONTINUOUS IMPERMEABLE BARRIER, SEDIMENT FENCING OR DIVERSION BUNDS ARE NOT REQUIRED.

SD - BLUE BOOK STANDARD DRAWING (LANDCOM, 2004)
 IECA SD - IECA STANDARD DRAWING (IECA, 2008)
 (REFER TO SEEC DRAWINGS 18000227_P02_ESCP001-003)

SLOPE LENGTHS ARE TO BE MAINTAINED AT MAXIMUM 40m INTERVALS ACROSS ALL EXPOSED SURFACES DURING RAINFALL (>50% CHANCE OF RAINFALL >10mm). EARTH CONTOUR BERMS, SANDBAG BUNDS OR SIMILAR IMPLEMENTED PRIOR TO RAINFALL CAN BE USED TO ACHIEVE THIS. NOTE THAT CURRENTLY IN MANY LOCATIONS THE NATURAL DIRECTION OF FALL ACROSS THE SITE ALREADY RESTRICTS SLOPE LENGTHS TO 40m OR LESS. HOWEVER, THIS WILL STILL NEED TO BE RE-ASSESSED AS WORKS PROGRESS AND LEVELS CHANGE.

REFER TO ESCP001-003 FOR INSTRUCTIONS, STANDARD DRAWINGS AND BACKGROUND INFORMATION.

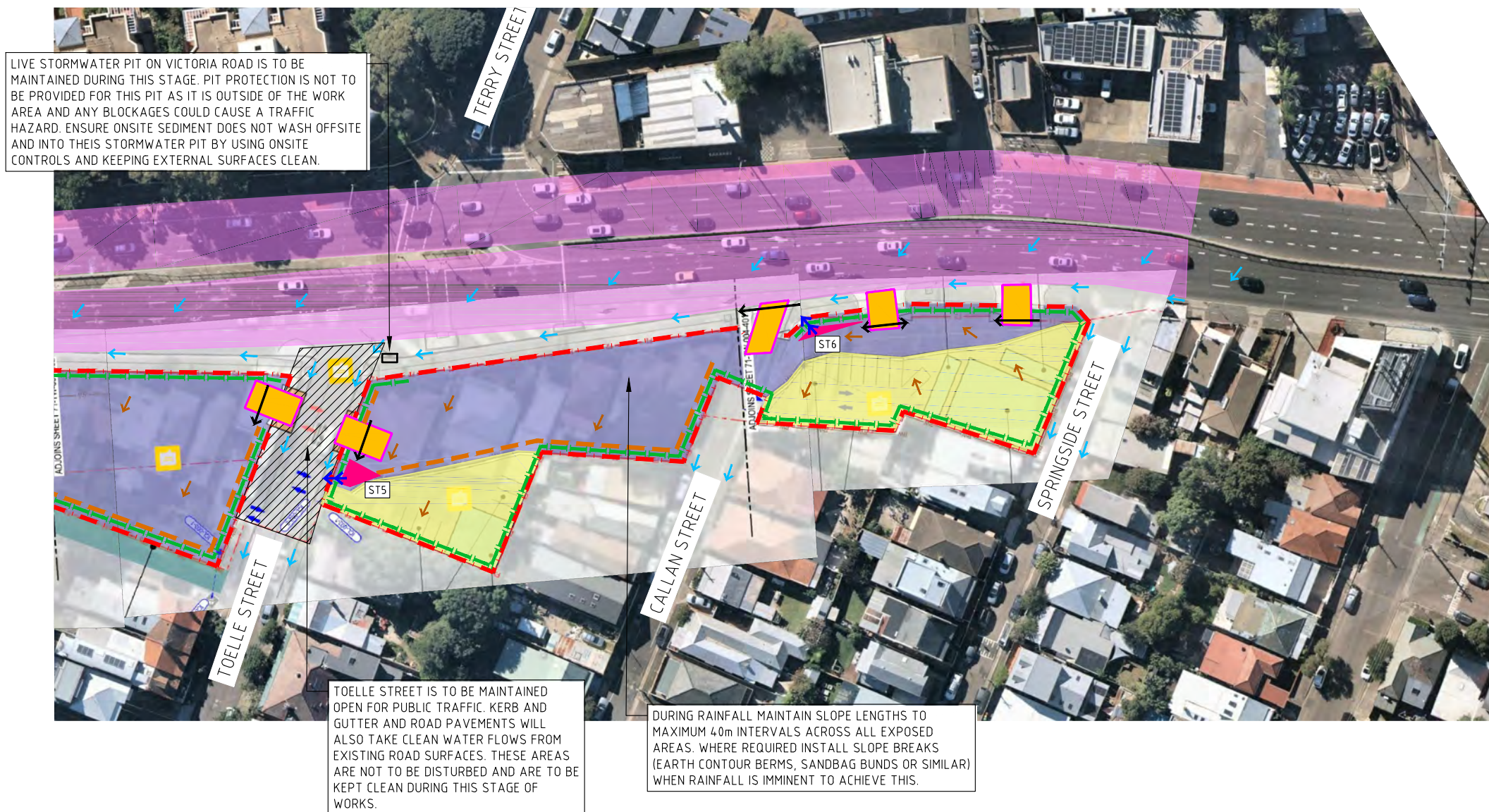

REV	DATE	DES.	DRN.	APP.	REVISION DETAILS
00	11/06/19	A.T.	A.T.	A.M.	FINAL - FOR USE
B	03/06/19	A.T.	A.T.	A.M.	REVISED DRAFT - FOR CONSULTATION
A	07/08/18	A.T.	A.T.	A.M.	DRAFT - FOR CONSULTATION

DRAWING STATUS	
DESIGN BY	A.T.
DRAWN BY	A.T.
FINAL APPROVAL	A.M.
SCALE:	1:1250
(on A3 Original)	
FINAL	

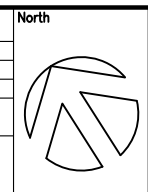

CLIENT

PO Box 1098, Bowral, NSW, 2576
 Suites 7 & 8, 68-70 Station Street
 Bowral NSW 2576.
 (t) 02 4862 1633
 (f) 02 4862 3088
 email: reception@seec.com.au
 WWW.SEEC.COM.AU

PROJECT TITLE

**WESTCONNEX
 STAGE 3B
 IRON COVE LINK CIVIL SITE**

DRAWING TITLE			
EROSION AND SEDIMENT CONTROL PLAN FOR INITIAL SITE ESTABLISHMENT			
PROJECT NO.	SUB-PR NO.	DRAWING NO.	REV
18000227	P02	ESCP102	00

EROSION HAZARD ASSESSMENT

FOLLOWING THE PROCEDURE DETAILED IN THE BLUE BOOK (VOLUMES 1 AND 2D), THE EROSION HAZARD HAS BEEN DETERMINED USING THE REVISED UNIVERSAL SOIL LOSS EQUATION (RUSLE) AS FOLLOWS:

$A = R \times K \times LS \times P \times C$

- A = SOIL LOSS (TONNES PER HECTARE PER YEAR)
- R = RAINFALL EROSIVITY (3480 FOR THIS SITE)
- K = SOIL ERODIBILITY (0.05 ASSUMED FOR THIS SITE - IMPORTED FILL)
- LS = SLOPE LENGTH AND GRADIENT (0.3 FOR THE DISTURBED AREAS OF THIS SITE, ASSUMING 1.5% AND 80M)
- P = SOIL CONSERVATION PRACTICES (1.3 ADOPTED FOR THE DISTURBED AREAS OF THIS SITE, ASSUMING COMPACTED GROUND)
- C = GROUND COVER (1.0 ADOPTED FOR THE DISTURBED AREAS OF THIS SITE, ASSUMING NO COVER).

USING THIS EQUATION AND THE ABOVE INPUTS, RUSLE PRODUCES A VALUE OF 67 T/HA/YR, WHICH IS VERY LOW.

BASED ON THE REQUIREMENTS IN BLUE BOOK VOLUME 2D, SEDIMENT BASINS WOULD BE REQUIRED FOR CATCHMENTS EXCEEDING 2.99 HA (I.E. WHERE THE TOTAL SOIL LOSS EXCEEDS 200 TONNES PER YEAR).

THE DISCRETE DISTURBANCE AREAS DURING SITE SETUP DO NOT EXCEED THIS THRESHOLD, SO SEDIMENT BASINS ARE NOT REQUIRED.

INSTRUCTIONS

1. INSTALL EROSION AND SEDIMENT CONTROLS AS NOTED ON THIS ESCP.
2. ENSURE EROSION AND SEDIMENT CONTROLS ARE IN PLACE PRIOR TO DISTURBANCE.
3. MINIMISE THE TIME AND EXTENT OF DISTURBANCE AT ANY ONE TIME.
4. WHEREVER POSSIBLE, REUSE EXISTING TRACKS FOR ACCESS.
5. AS MUCH AS POSSIBLE, REUSE THE MULCH PRESENTLY ONSITE TO CREATE MULCH BUNDS.
6. IN ADDITION TO THOSE CONTROLS NOTED, UNDERTAKE DUST SUPPRESSION AS REQUIRED TO MINIMISE THE RISK OF DUST RISE FROM THE SITE.
7. UNDERTAKE INSPECTIONS OF EROSION AND SEDIMENT CONTROLS AT LEAST ONCE A WEEK, AND BEFORE AND AFTER RAINFALL OF 5MM OR MORE IN 24 HOURS. REPAIR AND/OR CLEAN OUT CONTROLS AS REQUIRED.
8. ANY DEWATERING IS TO BE UNDERTAKEN IN ACCORDANCE WITH THE PROCEDURE DETAILED IN THE SWMP.

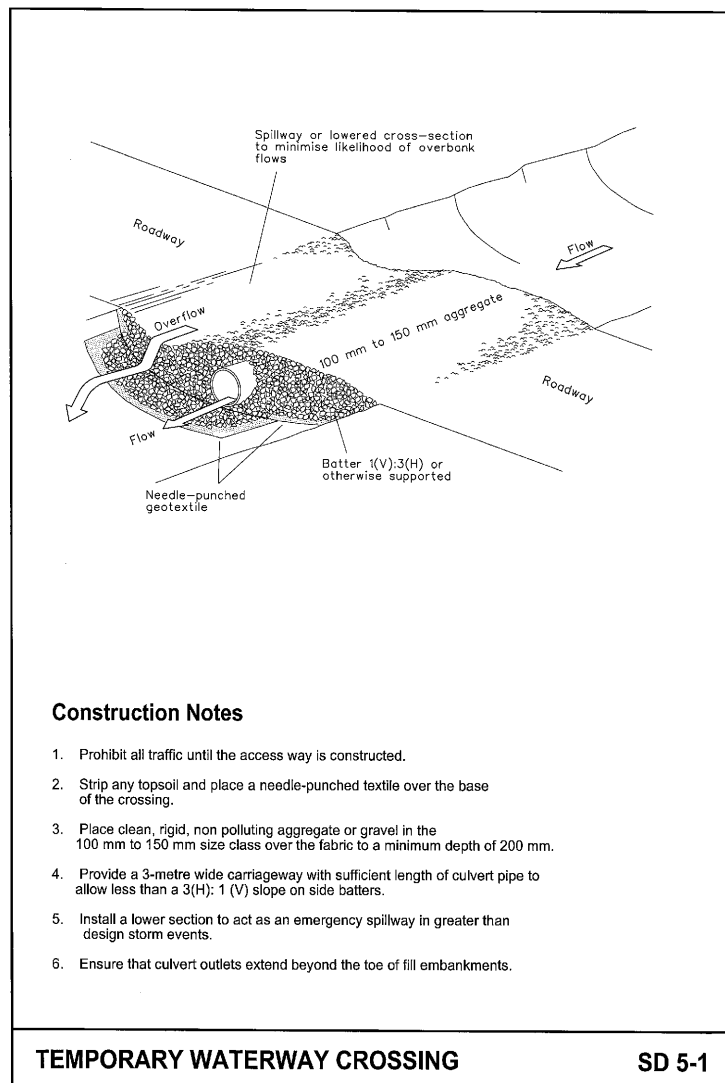

FROM LANDCOM (2004)

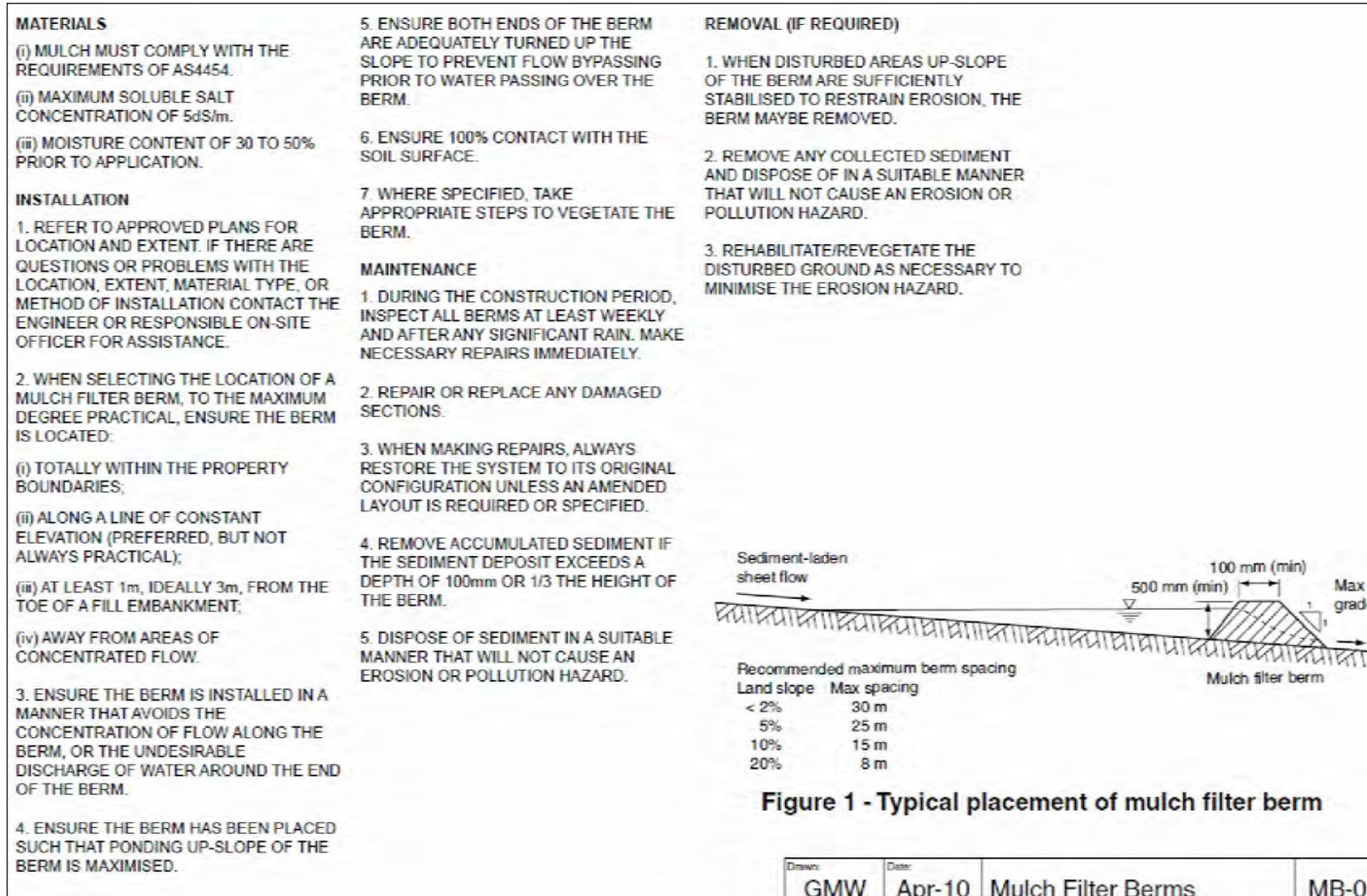

FROM IECA (2008)

REV	DATE	DES.	DRN.	APP.	REVISION DETAILS	DRAWING STATUS		North	CLIENT	PROJECT TITLE	DRAWING TITLE				
						DESIGN BY	C.B.			WEST CONNEX STAGE 3B M4-M5 LINK ROZELLE INTERCHANGE	EROSION AND SEDIMENT CONTROL PLAN				
					DRAWN BY	C.B.									
					FINAL APPROVAL	A.M.									
						SCALE:	1:1000								
						SCALED (on A3 Original)									
A	24/04/19	C.B.	C.B.	A.M.	DRAFT - FOR CONSULTATION	DRAFT						PROJECT NO.	SUB-PR NO.	DRAWING NO.	REV
												18000227	P01	ESCP00	A

This drawing is subject to COPYRIGHT ©. The information on this drawing remains the property of SEEC.

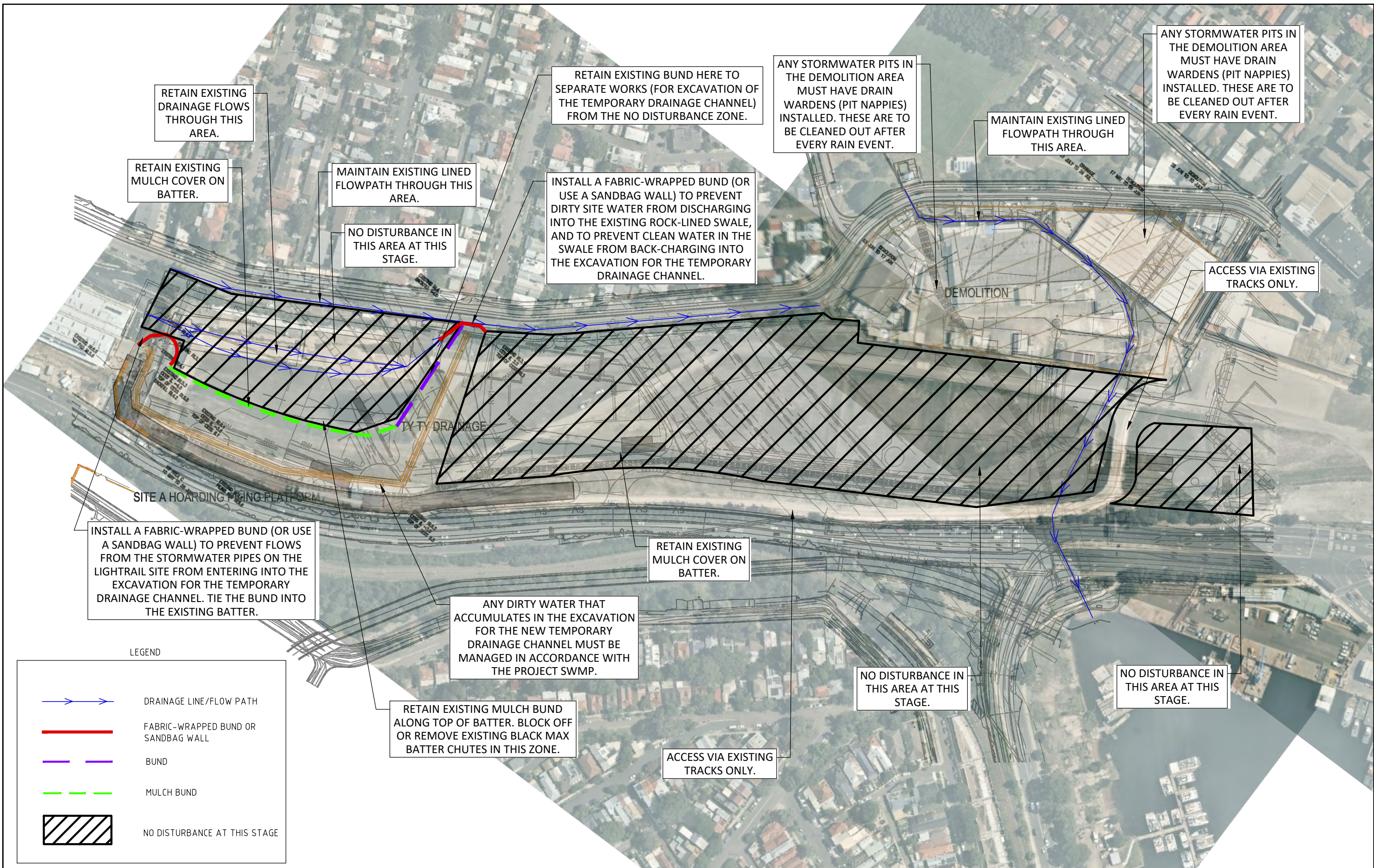

RETAIN EXISTING DRAINAGE FLOWS THROUGH THIS AREA.

RETAIN EXISTING MULCH COVER ON BATTER.

MAINTAIN EXISTING LINED FLOWPATH THROUGH THIS AREA.

NO DISTURBANCE IN THIS AREA AT THIS STAGE.

RETAIN EXISTING BUND HERE TO SEPARATE WORKS (FOR EXCAVATION OF THE TEMPORARY DRAINAGE CHANNEL) FROM THE NO DISTURBANCE ZONE.

INSTALL A FABRIC-WAPPED BUND (OR USE A SANDBAG WALL) TO PREVENT DIRTY SITE WATER FROM DISCHARGING INTO THE EXISTING ROCK-LINED SWALE, AND TO PREVENT CLEAN WATER IN THE SWALE FROM BACK-CHARGING INTO THE EXCAVATION FOR THE TEMPORARY DRAINAGE CHANNEL.

ANY STORMWATER PITS IN THE DEMOLITION AREA MUST HAVE DRAIN WARDENS (PIT NAPPIES) INSTALLED. THESE ARE TO BE CLEANED OUT AFTER EVERY RAIN EVENT.

MAINTAIN EXISTING LINED FLOWPATH THROUGH THIS AREA.

ANY STORMWATER PITS IN THE DEMOLITION AREA MUST HAVE DRAIN WARDENS (PIT NAPPIES) INSTALLED. THESE ARE TO BE CLEANED OUT AFTER EVERY RAIN EVENT.

ACCESS VIA EXISTING TRACKS ONLY.

INSTALL A FABRIC-WAPPED BUND (OR USE A SANDBAG WALL) TO PREVENT FLOWS FROM THE STORMWATER PIPES ON THE LIGHTRAIL SITE FROM ENTERING INTO THE EXCAVATION FOR THE TEMPORARY DRAINAGE CHANNEL. TIE THE BUND INTO THE EXISTING BATTER.

RETAIN EXISTING MULCH COVER ON BATTER.

ANY DIRTY WATER THAT ACCUMULATES IN THE EXCAVATION FOR THE NEW TEMPORARY DRAINAGE CHANNEL MUST BE MANAGED IN ACCORDANCE WITH THE PROJECT SWMP.





RETAIN EXISTING MULCH BUND ALONG TOP OF BATTER. BLOCK OFF OR REMOVE EXISTING BLACK MAX BATTER CHUTES IN THIS ZONE.

ACCESS VIA EXISTING TRACKS ONLY.

NO DISTURBANCE IN THIS AREA AT THIS STAGE.

NO DISTURBANCE IN THIS AREA AT THIS STAGE.

LEGEND

-  DRAINAGE LINE/FLOW PATH
-  FABRIC-WAPPED BUND OR SANDBAG WALL
-  BUND
-  MULCH BUND
-  NO DISTURBANCE AT THIS STAGE

REV	DATE	DES.	DRN.	APP.	REVISION DETAILS
A	24/04/19	C.B.	C.B.	A.M.	DRAFT - FOR CONSULTATION

DRAWING STATUS	
DESIGN BY	C.B.
DRAWN BY	C.B.
FINAL APPROVAL	A.M.
SCALE:	1:1000
(on A3 Original)	
DRAFT	

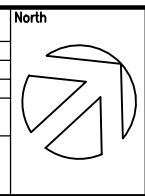

CLIENT



PO Box 1098, Bowral, NSW, 2576
 Suites 7 & 8, 68-70 Station Street
 Bowral NSW 2576.
 (t) 02 4862 1633
 (f) 02 4862 3088
 email: reception@seec.com.au
 WWW.SEEC.COM.AU

PROJECT TITLE
WEST CONNEX STAGE 3B M4-M5 LINK ROZELLE INTERCHANGE

DRAWING TITLE			
EROSION AND SEDIMENT CONTROL PLAN SITE ESTABLISHMENT-STG 1			
PROJECT NO.	SUB-PR NO.	DRAWING NO.	REV
18000227	P01	ESCP01	A

INSTALL A FABRIC-WRAPPED EARTH BUND (OR ROCK OR CONCRETE OR SIMILAR) TO DIVERT ALL UPSLOPE FLOWS INTO THE NEW TEMPORARY CHANNEL.

REUSE MULCH FROM THIS AREA TO FORM THE NEW MULCH BUNDS.

IF REQUIRED, BLOCK OFF THE EXISTING PIPE TO PREVENT BACKFLOW OF CLEAN WATER FROM THE ROCK-LINED SWALE INTO THE SITE A EARTHWORKS AREA.

RETAIN EXISTING MULCH COVER ON BATTER.

RETAIN EXISTING MULCH BUND ALONG TOP OF BATTER. BLOCK OFF OR REMOVE EXISTING BLACK MAX BATTER CHUTES IN THIS ZONE.

MAINTAIN EXISTING LINED FLOWPATH THROUGH THIS AREA.

ANY DIRTY WATER THAT ACCUMULATES IN THE EXCAVATION FOR THE DRAINAGE STRUCTURES MUST BE MANAGED IN ACCORDANCE WITH THE PROJECT SWMP.

USE SANDBAG WALLS (OR SIMILAR) TO CREATE BARRIERS TO PREVENT DIRTY SITE WATER FROM DRAINING INTO THE EXISTING STORMWATER CHANNEL.

NO DISTURBANCE IN THIS AREA AT THIS STAGE.

NEW TEMPORARY CHANNEL MUST BE 100% LINED (E.G. WITH FABRIC) PRIOR TO IT BEING MADE LIVE.

INSTALL MULCH BUNDS (MINIMUM 500MM HIGH) ALONG BOTH SIDES OF THE NEW TEMPORARY DRAINAGE CHANNEL. REFER TO DETAIL 1 FOR LIKELY PROFILE AND CROSS-SECTION. AS MUCH AS POSSIBLE, REUSE MULCH FROM THE AREA TO BE DISTURBED FOR SITE A EARTHWORKS.

ANY DIRTY WATER THAT ACCUMULATES IN THE EXCAVATION FOR THE DRAINAGE STRUCTURES MUST BE MANAGED IN ACCORDANCE WITH THE PROJECT SWMP.





INSTALL A TEMPORARY CROSSING POINT THROUGH THE TEMPORARY CHANNEL USING PIPES AND CLEAN ROCK. REFER TO BLUE BOOK STANDARD DETAIL 5-1.

REPOSITION MULCH FROM THIS SECTION OF BATTER TO CREATE A MULCH BUND ALONG THE TOE EDGE OF THE WORK ZONE.

NO CHANGE TO MULCH BUNDS AND BATTER CHUTES IN THIS ZONE.

INSTREAM WORKS MUST BE COMPLETED DURING DRY WEATHER ONLY - MONITOR WEATHER FORECASTS DAILY. PUMP ANY TRICKLE FLOWS AROUND THE WORK AREA. ENSURE A FULLY LINED FLOWPATH IS AVAILABLE FOR CLEAN WATER AT THE END OF EVERY DAY (USE FABRIC, SANDBAGS, SHOTCRETE ETC. AS REQUIRED).

LEGEND

-  DRAINAGE LINE/FLOW PATH
-  FABRIC-WRAPPED BUND OR SANDBAG WALL
-  BUND
-  MULCH BUND
-  NO DISTURBANCE AT THIS STAGE

REV	DATE	DES.	DRN.	APP.	REVISION DETAILS
A	24/04/19	C.B.	C.B.	A.M.	DRAFT - FOR CONSULTATION

DRAWING STATUS	
DESIGN BY	C.B.
DRAWN BY	C.B.
FINAL APPROVAL	A.M.
SCALE:	1:1000
(on A3 Original)	
DRAFT	

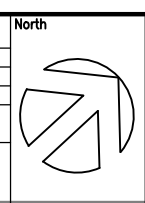

CLIENT





PO Box 1098, Bowral, NSW 2576
 Suites 7 & 8, 68-70 Station Street
 Bowral NSW 2576.
 (t) 02 4862 1633
 (f) 02 4862 3088
 email: reception@seec.com.au
 WWW.SEEC.COM.AU

PROJECT TITLE

**WEST CONNEX
 STAGE 3B
 M4-M5 LINK
 ROZELLE INTERCHANGE**

DRAWING TITLE			
EROSION AND SEDIMENT CONTROL PLAN SITE ESTABLISHMENT-STG 2			
PROJECT NO.	SUB-PR NO.	DRAWING NO.	REV
18000227	P01	ESCP02	A

This drawing is subject to COPYRIGHT ©. The information on this drawing remains the property of SEEC.

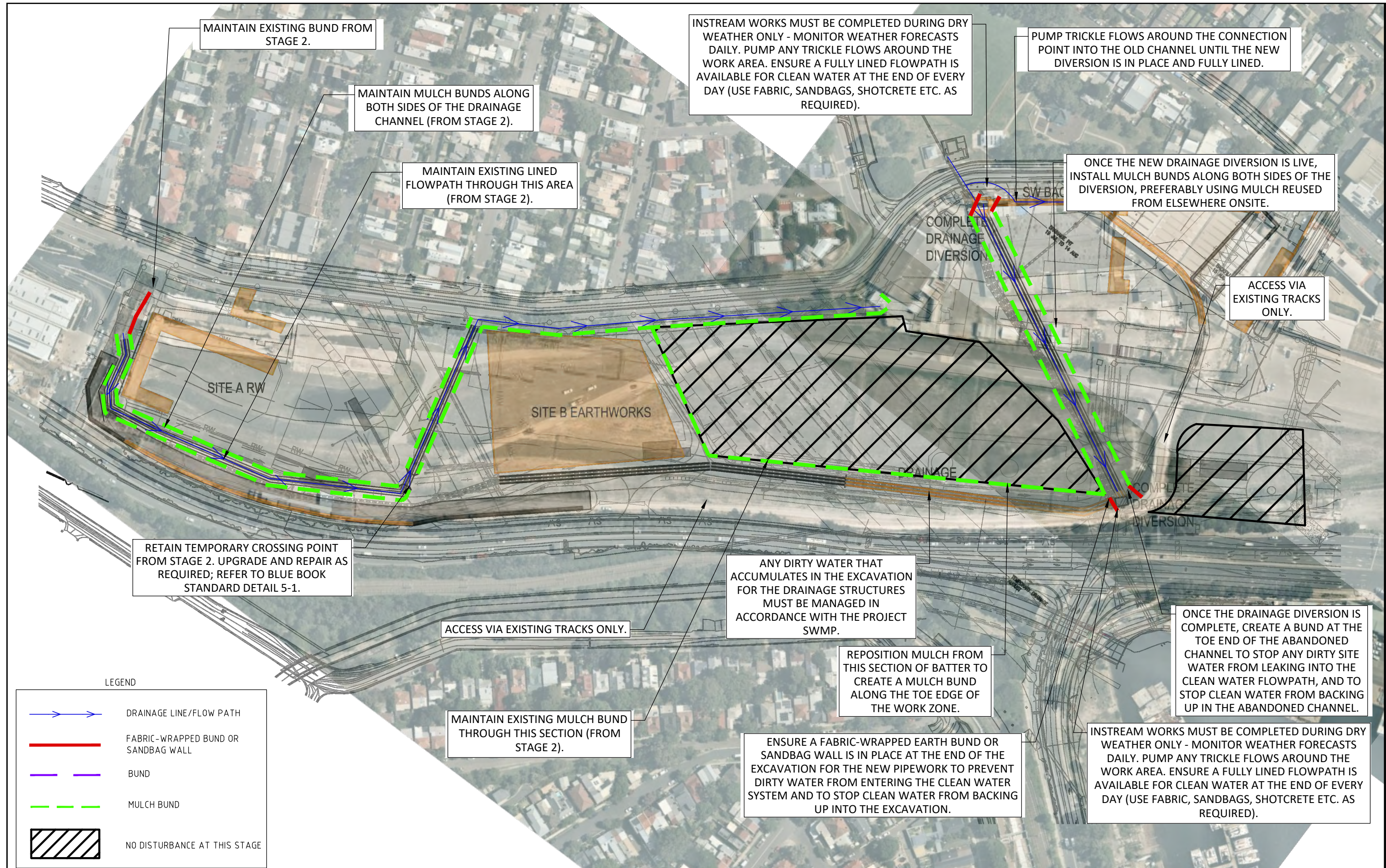

MAINTAIN EXISTING BUND FROM STAGE 2.

MAINTAIN MULCH BUNDS ALONG BOTH SIDES OF THE DRAINAGE CHANNEL (FROM STAGE 2).

MAINTAIN EXISTING LINED FLOWPATH THROUGH THIS AREA (FROM STAGE 2).

INSTREAM WORKS MUST BE COMPLETED DURING DRY WEATHER ONLY - MONITOR WEATHER FORECASTS DAILY. PUMP ANY TRICKLE FLOWS AROUND THE WORK AREA. ENSURE A FULLY LINED FLOWPATH IS AVAILABLE FOR CLEAN WATER AT THE END OF EVERY DAY (USE FABRIC, SANDBAGS, SHOTCRETE ETC. AS REQUIRED).

PUMP TRICKLE FLOWS AROUND THE CONNECTION POINT INTO THE OLD CHANNEL UNTIL THE NEW DIVERSION IS IN PLACE AND FULLY LINED.

ONCE THE NEW DRAINAGE DIVERSION IS LIVE, INSTALL MULCH BUNDS ALONG BOTH SIDES OF THE DIVERSION, PREFERABLY USING MULCH REUSED FROM ELSEWHERE ONSITE.

ACCESS VIA EXISTING TRACKS ONLY.

RETAIN TEMPORARY CROSSING POINT FROM STAGE 2. UPGRADE AND REPAIR AS REQUIRED; REFER TO BLUE BOOK STANDARD DETAIL 5-1.

ACCESS VIA EXISTING TRACKS ONLY.

ANY DIRTY WATER THAT ACCUMULATES IN THE EXCAVATION FOR THE DRAINAGE STRUCTURES MUST BE MANAGED IN ACCORDANCE WITH THE PROJECT SWMP.

REPOSITION MULCH FROM THIS SECTION OF BATTER TO CREATE A MULCH BUND ALONG THE TOE EDGE OF THE WORK ZONE.





ONCE THE DRAINAGE DIVERSION IS COMPLETE, CREATE A BUND AT THE TOE END OF THE ABANDONED CHANNEL TO STOP ANY DIRTY WATER FROM LEAKING INTO THE CLEAN WATER FLOWPATH, AND TO STOP CLEAN WATER FROM BACKING UP IN THE ABANDONED CHANNEL.

MAINTAIN EXISTING MULCH BUND THROUGH THIS SECTION (FROM STAGE 2).

ENSURE A FABRIC-WRAPPED EARTH BUND OR SANDBAG WALL IS IN PLACE AT THE END OF THE EXCAVATION FOR THE NEW PIPEWORK TO PREVENT DIRTY WATER FROM ENTERING THE CLEAN WATER SYSTEM AND TO STOP CLEAN WATER FROM BACKING UP INTO THE EXCAVATION.

INSTREAM WORKS MUST BE COMPLETED DURING DRY WEATHER ONLY - MONITOR WEATHER FORECASTS DAILY. PUMP ANY TRICKLE FLOWS AROUND THE WORK AREA. ENSURE A FULLY LINED FLOWPATH IS AVAILABLE FOR CLEAN WATER AT THE END OF EVERY DAY (USE FABRIC, SANDBAGS, SHOTCRETE ETC. AS REQUIRED).

LEGEND

-  DRAINAGE LINE/FLOW PATH
-  FABRIC-WRAPPED BUND OR SANDBAG WALL
-  BUND
-  MULCH BUND
-  NO DISTURBANCE AT THIS STAGE

REV	DATE	DES.	DRN.	APP.	REVISION DETAILS
A	24/04/19	C.B.	C.B.	A.M.	DRAFT - FOR CONSULTATION

DRAWING STATUS	
DESIGN BY	C.B.
DRAWN BY	C.B.
FINAL APPROVAL	A.M.
SCALE:	1:1000
(on A3 Original)	
DRAFT	

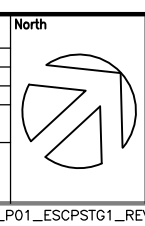

CLIENT



PO Box 1098, Bowral, NSW 2576
 Suites 7 & 8, 68-70 Station Street
 Bowral NSW 2576.
 (t) 02 4862 1633
 (f) 02 4862 3088
 email: reception@seec.com.au
 WWW.SEEC.COM.AU

PROJECT TITLE
**WEST CONNEX
 STAGE 3B
 M4-M5 LINK
 ROZELLE INTERCHANGE**

DRAWING TITLE			
EROSION AND SEDIMENT CONTROL PLAN SITE ESTABLISHMENT-STG 3			
PROJECT NO.	SUB-PR NO.	DRAWING NO.	REV
18000227	P01	ESCP03	A

This drawing is subject to COPYRIGHT ©. The information on this drawing remains the property of SEEC.